



2023  
—  
工具系统  
TOOLING SYSTEM



# 公司简介

## About GESAC

厦门金鹭特种合金有限公司，成立于1989年，是一家中外合资的国家高新技术企业，隶属于中国六大稀土集团之一的厦门钨业股份有限公司。公司致力于高品质钨粉末材料、硬质合金、精密切削工具等钨系列产品的研发、生产，以及行业专业解决方案的提供，是世界知名的钨粉末、硬质合金及切削工具供应商。

凭借完整钨产业链的产品集成技术研发，以及务实、创新的管理理念，厦门金鹭始终保持着强劲的发展势头，为全球用户提供最高性价比的产品和服务，为现代工业领域解决高硬度、耐高温、耐磨损问题，提供了优良的产品和完善的解决方案，客户遍布全球四十多个工业发达国家和地区，享誉海内外。

公司拥有国内4个生产基地和1个国家级企业研发中心，海外3个销售公司和1个海外生产基地，独立承担并完成多项“国家科技支撑计划项目”，“国家科技重大专项”，“国家火炬计划项目”，“国家重点新产品”开发项目及省市重点研究课题，被评为“战略性新兴产业骨干企业”、“创新型企业”、“先进技术企业”。

Xiamen Golden Egret Special Alloy Co., Ltd. (GESAC), founded in 1989, is a Sino-foreign joint venture with national high-tech, affiliated with XTC, which is one of six major rare earth groups in China. GESAC is committed to research & development, production and professional solutions providing of high-quality tungsten powder materials, cemented carbide, precision cutting tools and other tungsten products. Up to now, GESAC has become world-famous manufacturer and supplier of tungsten powder, cemented carbide and precision cutting tools products.

With the Integrated Product Development of complete tungsten industry chain, as well as a pragmatic and innovative management concept, GESAC has always maintained a strong momentum of development, providing the cost effective tungsten powder products and services for global users, offering the excellent products and perfect solutions for solving high hardness, high temperature resistance and wear resistance topics. Our brand "Golden Egret" has become one of the leading brand in the market, enjoying famous reputation in more than 40 countries and regions.

GESAC owns four production headquarters and one national level research center domestically, and three sales branches and one production base overseas. We undertook and completed several development programs independently, including the “National Science and Technology Support Programs”, the “National Torch Program Projects”, and the “National Key Projects” and so on. GESAC was awarded as "Key Enterprise for Strategic Emerging Industry", “Innovative Enterprise” and “Enterprise with Advanced Technology”.

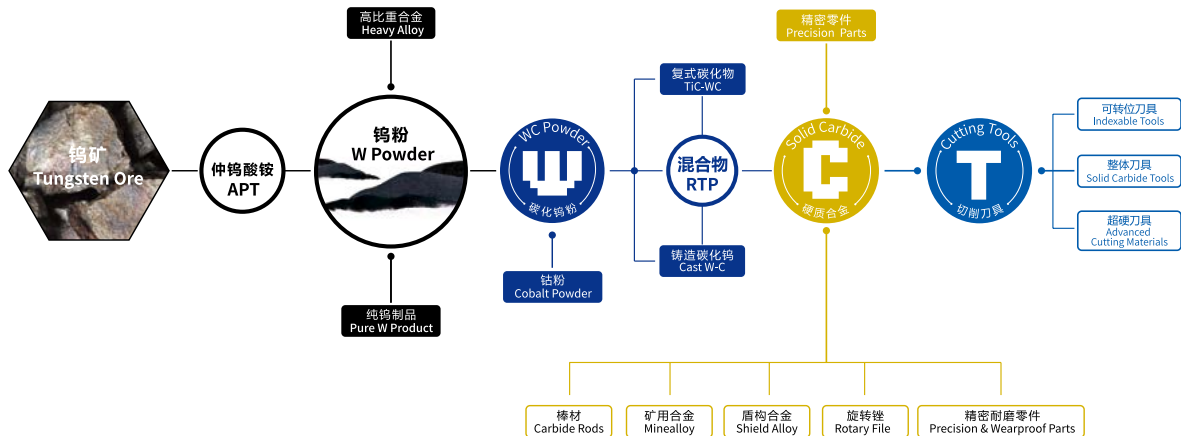

# 目录

## CONTENTS

### BT工具系统 BT Tooling System — A

液压刀柄 Hydraulic Chuck	06
热装刀柄 Shrink Fit Holder	08
高速精密筒夹刀柄 High Precision Collet Chuck	12
ER弹性筒夹刀柄 ER Spring Collet Chuck	13
强力筒夹刀柄 Power Milling Chuck For Heavy Duty	15
侧固式刀柄 Side-lock Holder	16
有扁尾莫氏圆锥孔刀柄 Morse Taper Holders with Tang	17
无扁尾莫氏圆锥孔刀柄 Morse Taper Holders without Tang	18
面铣刀刀柄 Face Mill Holder	19
三面刃铣刀刀柄 Solting Cutter Holders	21
一体式微补偿攻牙刀柄 Tapping Chuck	22

### HSK工具系统 HSK Tooling System — B

液压刀柄 Hydraulic Chuck	25
热装刀柄 Shrink Fit Holder	26
高速精密筒夹刀柄 High Precision Collet Chuck	30
ER弹性筒夹刀柄 ER Spring Collet Chuck	31
强力筒夹刀柄 Power Milling Chuck For Heavy Duty	33
侧固式刀柄 Side-lock Holder	34
侧固式刀柄 (2°) Side-lock Holder (2°)	35
有扁尾莫氏圆锥孔刀柄 Morse Taper Holders with Tang	36
面铣刀刀柄 Face Mill Holder	37
三面刃铣刀刀柄 Solting Cutter Holders	38
一体式微补偿攻牙刀柄 Tapping Chuck	39

## 配件 Accessories

## — C

延长杆 Extenders	41
筒夹 Collets	44
螺帽 Nuts	53
扳手 Wrenches	54
拉钉 Pull Studs	56

## 附录 Appendix

## — D

热缩刀柄使用注意事项 Announcements	59
刀柄尺寸图 Tool Holder Dimension	60

S  
T  
N  
E  
T  
N  
C

# BT30 — SF 06 — 200 L — S

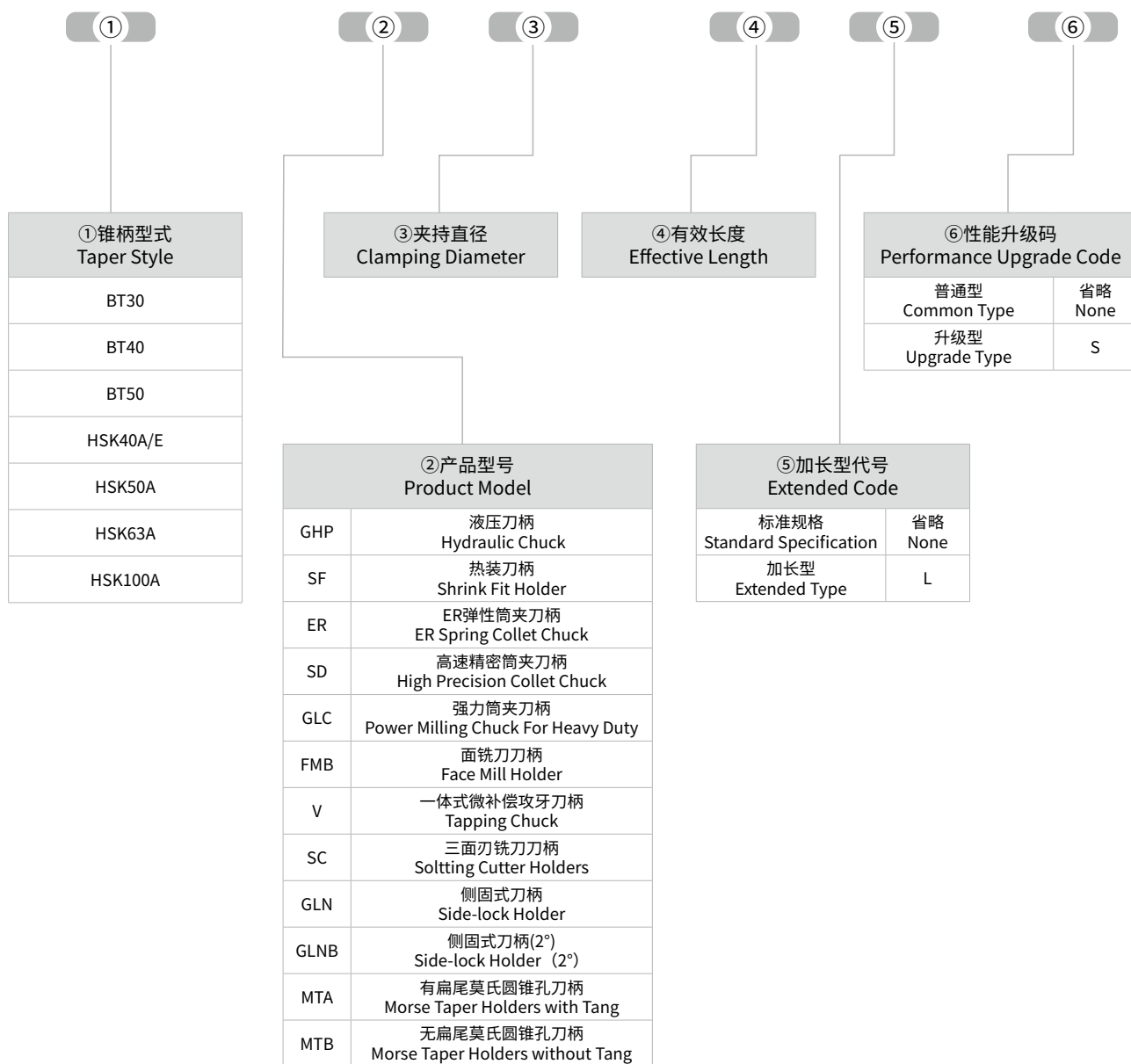

TOOLING SYSTEM



**BT 工具系统**

BT TOOLING SYSTEM

液压刀柄  
Hydraulic Chuck

# GHP

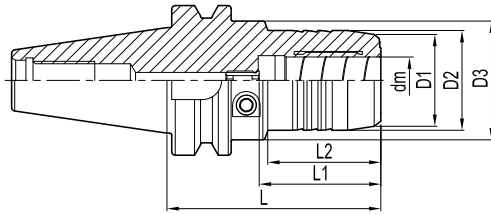

订货号 Ordering Code	尺寸 Dimension (mm)							筒夹 Collets	重量 Weight(kg)	库存 Stock	
	dm	D1	D2	D3	L	L1	L2				
BT30-	GHP06-50.8-S	6	23	26	46	50.8	37	15.6	-	0.6	○
	GHP08-50.8-S	8	25	28	46	50.8	37	15.6	-	0.6	○
	GHP10-50.8-S	10	27	30	46	50.8	41	15.6	-	0.6	○
	GHP12-50.8-S	12	29	32	46	50.8	46	15.6	OD12	0.6	○
	GHP14-90-S	14	30	34	50	90	46	40	-	0.9	○
	GHP16-90-S	16	34	38	50	90	49	50	-	1	○
	GHP18-90-S	18	36	40	50	90	49	47	-	1	○
	GHP20-90-S	20	38	42	50	90	51	50	OD20	1	●
BT40-	GHP06-65-S	6	22	26	50	65	37	18	-	1.2	○
	GHP06-90-S	6	22	26	50	90	37	43	-	1.4	●
	GHP06-140-S	6	22	26	50	140	37	93	-	1.6	○
	GHP08-65-S	8	24	28	50	65	37	20	-	1.3	○
	GHP08-90-S	8	24	28	50	90	37	44.5	-	1.4	●
	GHP08-140-S	8	24	28	50	140	37	94	-	1.6	○
	GHP10-65-S	10	26	30	50	65	41	21	-	1.3	○
	GHP10-90-S	10	26	30	50	90	41	44.5	-	1.4	●
	GHP10-140-S	10	26	30	50	140	41	94	-	1.7	○
	GHP12-65-S	12	28	32	53	65	46	22	OD12	1.3	○
	GHP12-90-S	12	28	32	50	90	46	44.5	OD12	1.4	●
	GHP12-140-S	12	28	32	50	140	46	95	OD12	1.8	○
	GHP14-65-S	14	30	34	56	65	46	22	-	1.3	○
	GHP14-90-S	14	30	34	50	90	46	44.5	-	1.5	●
	GHP14-140-S	14	30	34	50	140	46	95	-	1.8	○
	GHP16-65-S	16	34	38	56	65	49	20	-	1.4	○
	GHP16-90-S	16	34	38	50	90	49	47.5	-	1.5	●
	GHP16-140-S	16	34	38	50	140	49	96	-	1.9	○
	GHP18-75-S	18	36	40	60	75	49	30	-	1.4	○
	GHP18-90-S	18	36	40	50	90	49	47.5	-	1.5	○
	GHP18-140-S	18	36	40	50	140	49	97	-	1.9	○
	GHP20-75-S	20	38	50		75	51	48	OD20	1.5	○
	GHP20-90-S	20	38	42	50	90	51	47.5	OD20	1.6	●
	GHP20-140-S	20	38	42	50	140	51	97	OD20	2.1	○
GHP25-100-S	25	53	57	63	100	57	57	-	2.2	○	
GHP25-135-S	25	53	57	63	135	57	92	-	2.9	○	
GHP32-83-S	32	60	63	80	83	61	25.5	OD32	2	●	

●标准库存Stock ○需预定Available upon Order



液压刀柄  
Hydraulic Chuck

# GHP

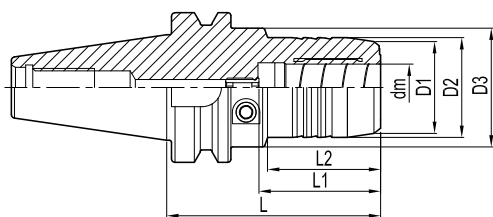

订货号 Ordering Code	尺寸 Dimension (mm)							筒夹 Collets	重量 Weight(kg)	库存 Stock	
	dm	D1	D2	D3	L	L1	L2				
BT40-	GHP32-135-S	32	60	63	75	135	61	85	OD32	3.2	○
BT50-	GHP06-90-S	6	22	26	50	90	37	29.5	-	4	○
	GHP06-120-S	6	22	26	50	120	37	34	-	4.1	○
	GHP06-140-S	6	22	26	50	140	37	34	-	4.3	○
	GHP08-90-S	8	24	28	50	90	37	30	-	3.9	○
	GHP08-120-S	8	24	28	50	120	37	34	-	4.1	○
	GHP08-140-S	8	24	28	50	140	37	34	-	4.2	○
	GHP10-90-S	10	26	30	50	90	41	31	-	4	○
	GHP10-120-S	10	26	30	50	120	41	34	-	4.2	○
	GHP10-140-S	10	26	30	50	140	41	34	-	4.3	○
	GHP12-90-S	12	28	32	50	90	46	34	OD12	4	●
	GHP12-120-S	12	28	32	50	120	46	65	OD12	4.2	○
	GHP12-140-S	12	28	32	50	140	46	95	OD12	4.3	○
	GHP14-90-S	14	30	34	44.5	90	46	34	-	4	○
	GHP14-120-S	14	30	34	50	120	46	64	-	4.1	○
	GHP14-140-S	14	30	34	50	140	46	84	-	4.3	○
	GHP16-90-S	16	34	38	44.5	90	49	34	-	4	○
	GHP16-120-S	16	34	38	50	120	49	65	-	4.3	○
	GHP16-140-S	16	34	38	50	140	49	85	-	4.4	○
	GHP18-90-S	18	36	40	44.5	90	49	34	-	4.1	○
	GHP18-120-S	18	36	40	50	120	49	62	-	4.3	○
	GHP18-140-S	18	36	40	50	140	49	82	-	4.5	○
	GHP20-90-S	20	38	42	44.5	90	51	34	OD20	4	●
	GHP20-120-S	20	38	42	50	120	51	65	OD20	4.3	○
	GHP20-140-S	20	38	42	50	140	51	85	OD20	4.6	○
	GHP25-105-S	25	40	44	72	105	61	49	-	4.8	○
	GHP25-150-S	25	40	44	72	150	61	93	-	5.6	○
GHP32-90-S	32	60	64	72	90	61	34	OD32	4.6	●	
GHP32-150-S	32	60	64	72	150	61	92	OD32	6	○	

●标准库存Stock ○需预定Available upon Order

注：扳手和筒夹需单独订购。

Notice: Wrench and collet shall be ordered separately.

附件Accessories	dm=6	dm=8	dm=10	dm=12	dm=16	dm=20	dm=25	dm=32
扳手Hex Wrench	TH05T-L-S						TH06T-L-S	

热装刀柄  
Shrink Fit Holder

SF

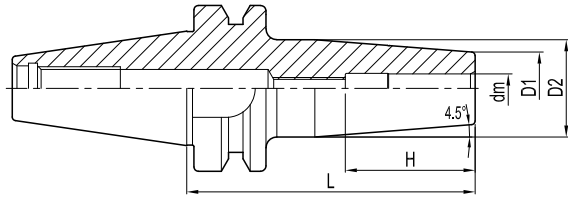

柄径公差  
h6

订货号 Ordering Code	尺寸 Dimension (mm)					重量 Weight(kg)	库存 Stock	
	dm	D1	D2	L	H			
BT30-	SF03-60-S	3	10	-	60	-	0.4	○
	SF04-60-S	4	10	-	60	-	0.4	●
	SF05-60-S	5	10	-	60	-	0.4	○
	SF06-80-S	6	21	27	80	36	0.6	●
	SF06-105-S	6	21	27	105	36	0.7	○
	SF06-120-S	6	21	27	120	36	0.7	○
	SF08-80-S	8	21	27	80	36	0.6	●
	SF08-105-S	8	21	27	105	36	0.8	○
	SF08-120-S	8	21	32	120	36	0.9	○
	SF10-80-S	10	24	32	80	42	0.6	●
	SF10-105-S	10	24	32	105	42	0.8	○
	SF10-120-S	10	24	32	120	42	0.9	○
	SF12-80-S	12	24	32	80	47	0.6	○
	SF12-105-S	12	24	32	105	47	0.8	○
	SF12-120-S	12	24	34	120	47	0.9	○
	SF14-80-S	14	27	34	80	47	0.7	○
	SF14-105-S	14	27	34	105	47	0.8	○
	SF14-120-S	14	27	34	120	47	0.9	○
	SF16-80-S	16	27	34	80	50	0.7	●
	SF16-105-S	16	27	34	105	50	0.8	○
SF16-120-S	16	27	34	120	50	0.9	○	
SF18-80-S	18	33	42	80	50	0.8	○	
SF20-90-S	20	33	42	90	52	0.9	○	
BT40-	SF03-80-S	3	10	-	80	-	1.0	○
	SF04-80-S	4	10	-	80	-	1.0	●
	SF05-80-S	5	10	-	80	-	1.0	○
	SF06-90-S	6	21	27	90	36	1.2	●
	SF06-120-S	6	21	27	120	36	1.3	●
	SF06-160-S	6	21	32	160	36	1.6	○
	SF06-200-S	6	21	32	200	36	1.9	○
	SF08-90-S	8	21	27	90	36	1.2	●
	SF08-120-S	8	21	27	120	36	1.3	●
	SF08-160-S	8	21	32	160	36	1.6	○
	SF08-200-S	8	21	32	200	36	1.9	○
	SF10-90-S	10	24	32	90	42	1.2	●

●标准库存Stock ○需预定Available upon Order

热装刀柄  
Shrink Fit Holder

SF

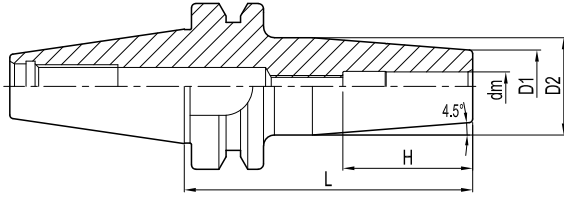

柄径公差  
h6

订货号 Ordering Code	尺寸 Dimension (mm)					重量 Weight(kg)	库存 Stock		
	dm	D1	D2	L	H				
BT40-	SF10-120-S	10	24	32	120	42	1.3	●	
	SF10-160-S	10	24	34	160	42	1.6	○	
	SF10-200-S	10	24	34	200	42	1.9	○	
	SF12-90-S	12	24	32	90	47	1.2	●	
	SF12-120-S	12	24	32	120	47	1.3	○	
	SF12-160-S	12	24	34	160	47	1.6	○	
	SF12-200-S	12	24	34	200	47	1.9	○	
	SF14-90-S	14	27	34	90	47	1.3	●	
	SF14-120-S	14	27	34	120	47	1.4	○	
	SF14-160-S	14	27	42	160	47	1.8	○	
	SF14-200-S	14	27	42	200	47	2.3	○	
	SF16-90-S	16	27	34	90	50	1.2	●	
	SF16-120-S	16	27	34	120	50	1.3	○	
	SF16-160-S	16	27	42	160	50	1.8	○	
	SF16-200-S	16	27	42	200	50	2.2	○	
	SF18-90-S	18	33	42	90	50	1.5	●	
	SF18-120-S	18	33	42	120	50	1.6	○	
	SF18-160-S	18	33	51	160	50	2.2	○	
	SF18-200-S	18	33	51	200	50	2.8	○	
	SF20-90-S	20	33	42	90	52	1.3	●	
	SF20-120-S	20	33	42	120	52	1.6	○	
	SF20-160-S	20	33	51	160	52	2.1	●	
	SF20-200-S	20	33	51	200	52	2.7	○	
	SF25-100-S	25	44	53	100	58	1.8	●	
	SF25-120-S	25	44	53	120	58	1.7	○	
	SF25-160-S	25	44	60	160	58	2.2	○	
	SF25-200-S	25	44	60	200	58	3.1	○	
	SF32-100-S	32	44	53	100	58	1.6	○	
	SF32-130-S	32	44	53	130	58	2.1	○	
	SF32-160-S	32	44	60	160	58	2.6	○	
	BT50-	SF06-100-S	6	21	27	100	36	3.7	●
		SF06-120-S	6	21	27	120	36	3.8	○
SF06-160-S		6	21	32	160	36	4.1	○	
SF06-200-S		6	21	32	200	36	4.4	○	

●标准库存Stock ○需预定Available upon Order

热装刀柄  
Shrink Fit Holder

SF

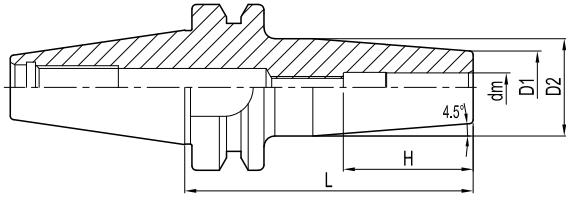

柄径公差  
h6

订货号 Ordering Code	尺寸 Dimension (mm)					重量 Weight(kg)	库存 Stock
	dm	D1	D2	L	H		
SF08-100-S	8	21	27	100	36	3.7	●
SF08-120-S	8	21	27	120	36	3.8	○
SF08-160-S	8	21	32	160	36	4.1	○
SF08-200-S	8	21	32	200	36	4.4	○
SF10-100-S	10	24	32	90	42	3.8	●
SF10-120-S	10	24	32	120	42	3.9	○
SF10-160-S	10	24	34	160	42	4.2	●
SF10-200-S	10	24	34	200	42	4.5	○
SF12-100-S	12	24	32	90	47	3.8	●
SF12-120-S	12	24	32	120	47	3.9	○
SF12-160-S	12	24	34	160	47	4.2	○
SF12-200-S	12	24	34	200	47	4.5	○
SF14-100-S	14	27	34	90	47	3.9	●
SF14-120-S	14	27	34	120	47	4	○
SF14-160-S	14	27	42	160	47	4.4	○
SF14-200-S	14	27	42	200	47	4.9	○
SF16-100-S	16	27	34	90	50	3.8	●
SF16-120-S	16	27	34	120	50	3.9	○
SF16-160-S	16	27	42	160	50	4.4	○
SF16-200-S	16	27	42	200	50	4.8	○
SF18-100-S	18	33	42	90	50	4.1	●
SF18-120-S	18	33	42	120	50	4.2	○
SF18-160-S	18	33	51	160	50	4.8	○
SF18-200-S	18	33	51	200	50	5.4	○
SF20-100-S	20	33	42	90	52	3.9	●
SF20-120-S	20	33	42	120	52	4.2	○
SF20-160-S	20	33	51	160	52	4.7	○
SF20-200-S	20	33	51	200	52	5.3	○
SF25-110-S	25	44	53	110	58	4.4	●
SF25-135-S	25	44	60	135	58	4.3	○
SF25-160-S	25	44	60	160	58	4.8	○
SF25-200-S	25	44	60	200	58	5.7	○
SF32-110-S	32	44	53	110	58	4.2	○
SF32-135-S	32	44	60	135	58	4.7	○

●标准库存Stock ○需预定Available upon Order

热装刀柄  
Shrink Fit Holder

SF

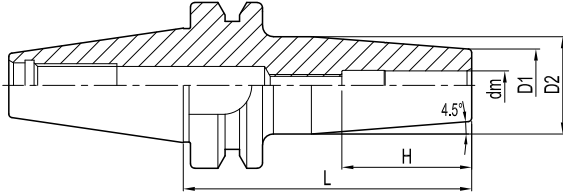

柄径公差  
h6

订货号 Ordering Code	尺寸 Dimension (mm)					重量 Weight(kg)	库存 Stock	
	dm	D1	D2	L	H			
BT50-	SF32-160-S	32	44	60	160	58	5.2	○
	SF32-200-S	32	44	60	200	58	6.1	○

●标准库存Stock ○需预定Available upon Order

特点  
Feature

动平衡设定 Balanced	3D处径向跳动 Runout (X3D)
G2.5; 25,000 rpm	0.003 mm

高速精密筒夹刀柄  
High Precision Collet Chuck

SD

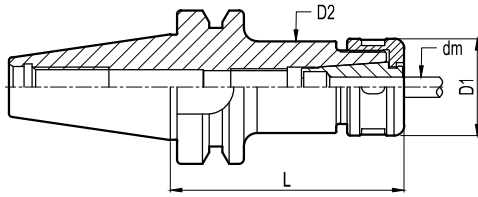

订货号 Ordering Code	尺寸 Dimension (mm)				筒夹 Collets	重量 Weight(kg)	库存 Stock	
	dm	D1	D2	L				
BT30-	SD06-70-S	1.8~6	19.5	20	70	SD06	0.7	○
	SD06-100-S	1.8~6	19.5	20	100	SD06	0.8	○
	SD10-70-S	1.75~10	27	27.5	70	SD10	1.0	○
	SD10-100-S	1.75~10	27	27.5	100	SD10	1.0	○
	SD16-70-S	2.75~16	40	40.5	70	SD16	1.2	○
	SD16-100-S	2.75~16	40	40.5	100	SD16	1.2	○
	SD16-120-S	2.75~16	40	40.5	120	SD16	1.3	○
	SD16-150-S	2.75~16	40	40.5	150	SD16	1.4	○
	SD20-70-S	3.0~20	48	48.5	70	SD20	0.9	○
	SD20-100-S	3.0~20	48	48.5	100	SD20	1.3	○
BT40-	SD06-70-S	1.8~6	19.5	20	70	SD06	1.0	○
	SD06-100-S	1.8~6	19.5	20	100	SD06	1.1	○
	SD06-120-S	1.8~6	19.5	20	120	SD06	1.4	○
	SD10-70-S	1.75~10	27	27.5	70	SD10	1.2	○
	SD10-100-S	1.75~10	27	27.5	100	SD10	1.3	○
	SD10-120-S	1.75~10	27	27.5	120	SD10	1.4	○
	SD10-150-S	1.75~10	27	27.5	150	SD10	1.6	○
	SD16-70-S	2.75~16	40	40.5	70	SD16	1.4	○
	SD16-100-S	2.75~16	40	40.5	100	SD16	1.5	○
	SD16-120-S	2.75~16	40	40.5	120	SD16	1.7	○
	SD20-70-S	3.0~20	48	48.5	70	SD20	1.4	○
	SD20-100-S	3.0~20	48	48.5	100	SD20	1.6	○
	SD20-120-S	3.0~20	48	48.5	120	SD20	2.0	○
SD20-150-S	3.0~20	48	48.5	150	SD20	2.4	○	
BT50-	SD10-105-S	1.75~10	27	27.5	105	SD10	4.2	○
	SD10-135-S	1.75~10	27	27.5	135	SD10	4.4	○
	SD10-165-S	1.75~10	27	27.5	165	SD10	4.6	○
	SD16-100-S	2.75~16	40	40.5	100	SD16	4.7	○
	SD16-125-S	2.75~16	40	40.5	125	SD16	4.8	○
	SD16-150-S	2.75~16	40	40.5	150	SD16	5.0	○
	SD20-100-S	3.0~20	48	48.5	100	SD20	4.3	○
	SD20-125-S	3.0~20	48	48.5	125	SD20	4.6	○
SD20-150-S	3.0~20	48	48.5	150	SD20	4.9	○	

注：筒夹与扳手需单独另购

Notice: Collets and wrenches shall be ordered separately.

●标准库存Stock ○需预定Available upon Order

ER弹性筒夹刀柄  
ER Spring Collet Chuck

ER

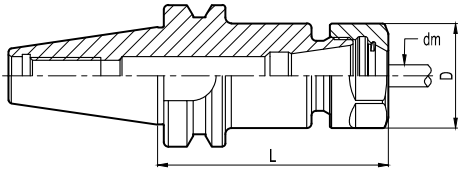

订货号 Ordering Code	尺寸 Dimension (mm)			重量 Weight(kg)	库存 Stock	
	dm	D	L			
BT30-	ER11-60-S	0.5~7	19	60	0.4	○
	ER11-90-S	0.5~7	19	90	0.5	●
	ER16-60-S	0.5~10	28	60	0.5	●
	ER16-90-S	0.5~10	28	90	0.6	●
	ER16-120-S	0.5~10	28	120	0.7	○
	ER20-60-S	1.0~13	34	60	0.5	●
	ER20-90-S	1.0~13	34	90	0.7	●
	ER20-120-S	1.0~13	34	120	0.9	○
	ER25-60-S	1.0~16	42	60	0.7	●
	ER25-90-S	1.0~16	42	90	0.9	●
	ER25-120-S	1.0~16	42	120	1.2	○
	ER32-60-S	2.0~20	50	60	0.6	●
	ER32-90-S	2.0~20	50	90	0.9	●
	BT40-	ER11-70-S	0.5~7	19	70	1
ER11-120-S		0.5~7	19	120	1.1	●
ER16-70-S		0.5~10	28	70	1.1	●
ER16-100-S		0.5~10	28	100	1.2	●
ER16-120-S		0.5~10	28	120	1.3	●
ER16-150-S		0.5~10	28	150	1.4	●
ER20-80-S		1.0~13	34	80	1.2	●
ER20-100-S		1.0~13	34	100	1.3	●
ER20-120-S		1.0~13	34	120	1.4	●
ER20-150-S		1.0~13	34	150	1.7	●
ER25-80-S		1.0~16	42	80	1.3	●
ER25-100-S		1.0~16	42	100	1.5	●
ER25-120-S		1.0~16	42	120	1.7	●
ER25-150-S		1.0~16	42	150	2	●
ER32-60-S		2.0~20	50	60	1.1	●
ER32-100-S		2.0~20	50	100	1.7	●
ER32-150-S		2.0~20	50	150	2.4	●
ER40-80-S		3.0~26	63	80	1.5	●
ER40-100-S		3.0~26	63	100	1.9	●
ER40-120-S		3.0~26	63	120	2.3	○

●标准库存Stock ○需预定Available upon Order

ER弹性筒夹刀柄  
ER Spring Collet Chuck

# ER

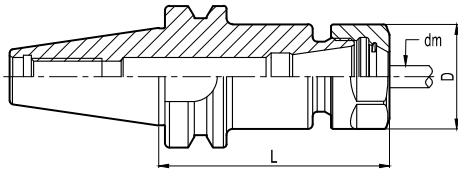

订货号 Ordering Code		尺寸 Dimension (mm)			重量 Weight(kg)	库存 Stock
		dm	D	L		
BT40-	ER40-150-S	3.0~26	63	150	2.9	○
BT50-	ER16-80-S	0.5~10	28	80	3.7	○
	ER16-100-S	0.5~10	28	100	3.8	●
	ER16-120-S	0.5~10	28	120	3.8	○
	ER16-165-S	0.5~10	28	165	4	○
	ER20-80-S	1.0~13	34	80	3.7	○
	ER20-100-S	1.0~13	34	100	3.8	●
	ER20-135-S	1.0~13	34	135	4	○
	ER20-165-S	1.0~13	34	165	4.2	●
	ER20-200-S	1.0~13	34	200	4.4	○
	ER20-250-S	1.0~13	34	250	4.7	○
	ER25-80-S	1.0~16	42	80	3.8	●
	ER25-100-S	1.0~16	42	100	3.9	●
	ER25-120-S	1.0~16	42	120	4.1	●
	ER25-165-S	1.0~16	42	165	4.5	●
	ER25-200-S	1.0~16	42	200	4.9	○
	ER25-250-S	1.0~16	42	250	5.3	○
	ER32-90-S	2.0~20	50	90	3.9	●
	ER32-100-S	2.0~20	50	100	4	●
	ER32-120-S	2.0~20	50	120	4.3	●
	ER32-165-S	2.0~20	50	165	4.9	●
	ER32-200-S	2.0~20	50	200	5.4	●
	ER32-250-S	2.0~20	50	250	6.3	●
	ER40-100-S	3.0~26	63	100	4.3	●
	ER40-120-S	3.0~26	63	120	4.8	○
	ER40-165-S	3.0~26	63	165	5.9	●
	ER40-200-S	3.0~26	63	200	6.7	○

注：筒夹与扳手需单独另购

Notice: Collets and wrenches shall be ordered separately.

●标准库存Stock ○需预定Available upon Order



强力筒夹刀柄  
Power Milling Chuck For Heavy Duty

# GLC

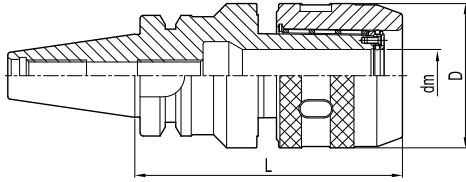

订货号 Ordering Code	尺寸 Dimension (mm)			筒夹 Collets	重量 Weight(kg)	库存 Stock	
	dm	D	L				
BT30- GLC20-95-S	20	55	95	GC20	1.4	○	
BT40-	GLC20-80-S	20	55	80	GC20	1.9	○
	GLC20-95-S	20	55	95	GC20	1.9	●
	GLC20-120-S	20	55	120	GC20	2.3	○
	GLC32-105-S	32	72	105	GC32	2.6	●
	GLC32-135-S	32	72	135	GC32	3.6	○
BT50-	GLC20-105-S	20	55	105	GC20	4.4	●
	GLC20-135-S	20	55	135	GC20	5	○
	GLC25-110-S	25	62	110	GC25	4.6	●
	GLC25-135-S	25	62	135	GC25	5.3	○
	GLC32-110-S	32	72	110	GC32	5.1	●
	GLC32-135-S	32	72	135	GC32	5.8	●
	GLC32-165-S	32	72	165	GC32	6.7	○
	GLC32-200-S	32	72	200	GC32	7.8	○
	GLC42-110-S	42	87	110	GC42	5.7	●
	GLC42-135-S	42	87	135	GC42	6.9	○
GLC42-165-S	42	87	165	GC42	8.1	○	

注：筒夹与扳手需单独另购

Notice: Collets and wrenches shall be ordered separately.

●标准库存Stock ○需预定Available upon Order

侧固式刀柄  
Side-lock Holder

# GLN

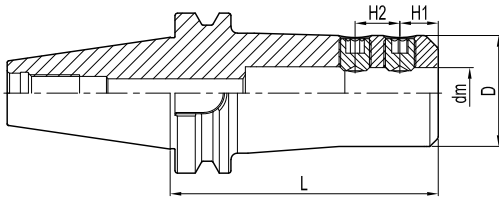

订货号 Ordering Code		尺寸 Dimension (mm)					侧固螺钉 Screws	重量 Weight(kg)	库存 Stock
		dm	D	L	H1	H2			
BT30-	GLN16-60-S	16	46	60	24	-	STCM140160-S	0.79	●
	GLN20-80-S	20	52	80	25	-	STCM160160-S	1.04	●
BT40-	GLN16-65-S	16	48	65	24	-	STCM140160-S	1.35	●
	GLN20-75-S	20	52	75	25	-	STCM160160-S	1.54	●
	GLN25-105-S	25	65	105	24	25	STCM180160-S	2.5	●
	GLN32-110-S	32	72	110	24	28	STCM200160-S	2.84	●
BT50-	GLN16-100-S	16	48	100	24	-	STCM140160-S	4.21	●
	GLN20-75-S	20	52	75	25	-	STCM160160-S	3.95	○
	GLN20-100-S	20	52	100	25	-	STCM160160-S	4.28	●
	GLN25-115-S	25	65	115	24	25	STCM180200-S	5.06	●
	GLN25-150L-S	25	65	150	24	25	STCM180200-S	5.89	○
	GLN32-115-S	32	72	115	24	28	STCM200200-S	5.28	●
	GLN32-150L-S	32	72	150	24	28	STCM200200-S	6.39	○
	GLN40-115-S	40	90	115	30	32	STCM200250-S	6.18	●
	GLN50-125-S	50	100	125	35	35	STCM240250-S	6.94	●

●标准库存Stock ○需预定Available upon Order

注：筒夹与扳手需单独另购

Notice: Collets and wrenches shall be ordered separately.

有扁尾莫氏圆锥孔刀柄  
Morse Taper Holder with Tang

# MTA

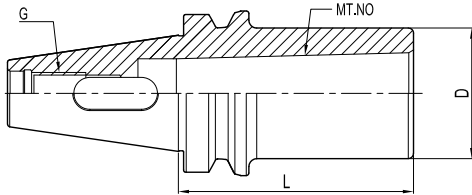

订货号 Ordering Code		尺寸 Dimension (mm)				重量 Weight(kg)	库存 Stock
		MT	L	D	G		
BT30-	MTA1-45-S	1	45	25	M12	0.39	○
	MTA2-60-S	2	60	32	M12	0.46	○
	MTA3-80-S	3	80	40	M12	0.60	○
BT40-	MTA1-45-S	1	45	25	M16	0.96	○
	MTA1-120-S	1	120	25	M16	1.27	○
	MTA2-45-S	2	45	32	M16	0.96	○
	MTA2-120-S	2	120	32	M16	1.41	○
	MTA3-75-S	3	75	40	M16	1.15	○
	MTA3-135-S	3	135	40	M16	1.72	○
	MTA4-90-S	4	90	50	M16	1.33	○
BT50-	MTA1-45-S	1	45	25	M24	3.50	○
	MTA1-120-S	1	120	25	M24	3.86	○
	MTA2-45-S	2	45	32	M24	3.44	○
	MTA2-135-S	2	135	32	M24	4.06	○
	MTA2-180-S	2	180	32	M24	4.36	○
	MTA3-45-S	3	45	40	M24	3.99	○
	MTA3-150-S	3	150	40	M24	4.39	○
	MTA3-180-S	3	180	40	M24	4.69	○
	MTA4-75-S	4	75	50	M24	3.36	○
	MTA4-180-S	4	180	50	M24	3.66	○
	MTA5-105-S	5	105	70	M24	4.08	○

●标准库存Stock ○需预定Available upon Order

无扁尾莫氏圆锥孔刀柄  
Morse Taper Holder without Tang

# MTB

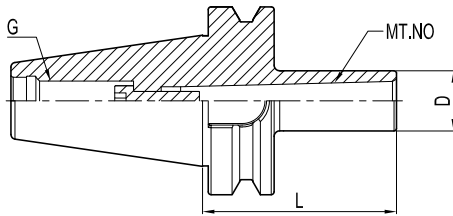

订货号 Ordering Code		尺寸 Dimension (mm)				重量 Weight(kg)	库存 Stock
		MT	L	D	G		
BT40-	MTB1-45-S	1	45	25	M16	1.01	○
	MTB2-60-S	2	60	32	M16	1.09	○
	MTB3-75-S	3	75	40	M16	1.22	○
	MTB4-90-S	4	90	50	M16	1.26	○
BT50-	MTB1-45-S	1	45	25	M24	3.54	○
	MTB2-45-S	2	45	32	M24	3.56	○
	MTB3-60-S	3	60	40	M24	3.61	○
	MTB4-75-S	4	75	50	M24	3.73	○
	MTB5-120-S	5	120	65	M24	4.30	○

注：报价时不含拉紧拉钉。

Notice: Tension screw is not included.

●标准库存Stock ○需预定Available upon Order

面铣刀刀柄  
Face Mill Holder

# FMB

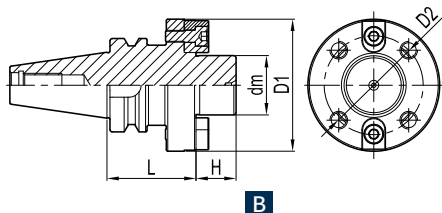
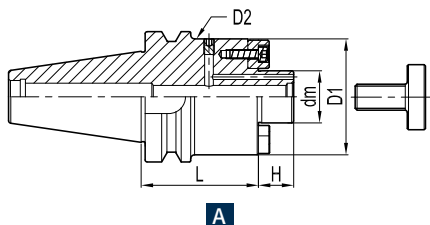

订货号 Ordering Code	图示 Figure	尺寸 Dimension (mm)					压紧螺钉 Screw	重量 Weight(kg)	库存 Stock	
		dm	D1	D2	L	H				
BT30-	FMB16C-60-S	A	16	34	-	60	17	SCAM080300-S	0.7	●
	FMB22C-45-S	A	22	42	-	45	19	SCAM100300-S	0.7	●
	FMB27C-45-S	A	27	60	-	45	21	SXM27-S	1	○
	FMB32C-50-S	A	32	78	-	50	24	SXM32-S	1.5	○
BT40-	FMB16C-60-S	A	16	34	-	60	17	SCAM080300-S	1.3	●
	FMB16C-90-S	A	16	34	-	90	17	SCAM080300-S	1.5	○
	FMB16C-120-S	A	16	34	-	120	17	SCAM080300-S	1.7	○
	FMB22C-60-S	A	22	42	-	60	19	SCAM100300-S	1.4	●
	FMB22C-90-S	A	22	42	-	90	19	SCAM100300-S	1.7	●
	FMB22C-120-S	A	22	42	-	120	19	SCAM100300-S	2.1	●
	FMB22C-150L-S	A	22	42	60	150	19	SCAM100300-S	3	○
	FMB22C-200L-S	A	22	42	60	200	19	SCAM100300-S	3.8	○
	FMB22C-250L-S	A	22	42	60	250	19	SCAM100300-S	4.6	○
	FMB22C-300L-S	A	22	42	60	300	19	SCAM100300-S	5.5	○
	FMB27C-60-S	A	27	60	-	60	21	SXM27-S	1.9	●
	FMB27C-90-S	A	27	60	-	90	21	SXM27-S	2.5	○
	FMB27C-120-S	A	27	60	-	120	21	SXM27-S	3.2	○
	FMB32C-60-S	A	32	78	-	60	24	SXM32-S	2.3	●
FMB32C-100-S	A	32	78	-	100	24	SXM32-S	2.8	○	
FMB40C-60-S	A	40	89	-	60	27	SXM40-S	2.7	●	
BT50-	FMB16C-60-S	A	16	34	-	60	17	SCAM080300-S	3.7	○
	FMB16C-90-S	A	16	34	-	90	17	SCAM080300-S	3.9	○
	FMB16C-120-S	A	16	34	-	120	17	SCAM080300-S	4.1	●
	FMB22C-60-S	A	22	42	-	60	19	SCAM100300-S	4	●
	FMB22C-90-S	A	22	42	-	90	19	SCAM100300-S	4.2	●
	FMB22C-150L-S	A	22	42	60	150	19	SCAM100300-S	5.5	○
	FMB22C-200L-S	A	22	42	60	200	19	SCAM100300-S	6.2	○
	FMB22C-250L-S	A	22	42	60	250	19	SCAM100300-S	7	○
	FMB22C-300L-S	A	22	42	60	300	19	SCAM100300-S	7.8	○
FMB27C-60-S	A	27	60	-	60	21	SXM27-S	4.3	●	

●标准库存Stock ○需预定Available upon Order

面铣刀刀柄  
Face Mill Holder

# FMB

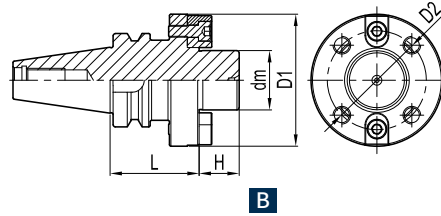
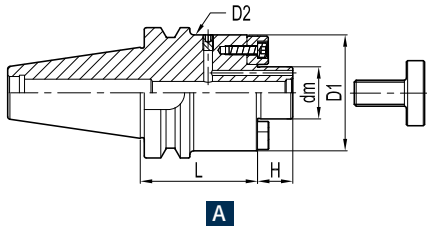

订货号 Ordering Code	图示 Figure	尺寸 Dimension (mm)					压紧螺钉 Screw	重量 Weight(kg)	库存 Stock	
		dm	D1	D2	L	H				
BT50-	FMB27C-90-S	A	27	60	-	90	21	SXM27-S	4.8	●
	FMB27C-120-S	A	27	60	-	120	21	SXM27-S	5.6	●
	FMB27C-150L-S	A	27	60	75	150	21	SXM27-S	6.8	●
	FMB27C-200L-S	A	27	60	75	200	21	SXM27-S	8.2	●
	FMB27C-250L-S	A	27	60	75	250	21	SXM27-S	9.8	○
	FMB27C-300L-S	A	27	60	75	300	21	SXM27-S	11	○
	FMB32C-60-S	A	32	78	-	60	24	SXM32-S	4.7	●
	FMB32C-90-S	A	32	78	-	90	24	SXM32-S	5.8	●
	FMB32C-150-S	A	32	78	-	150	24	SXM32-S	8	●
	FMB32C-200-S	A	32	78	-	200	24	SXM32-S	9.8	○
	FMB40C-60-S	A	40	89	-	60	27	SXM40-S	5.2	●
	FMB40C-75-S	A	40	89	-	75	27	SXM40-S	5.8	●
	FMB40C-90-S	A	40	89	-	90	27	SXM40-S	6.5	●
	FMB40C-120-S	A	40	89	-	120	27	SXM40-S	7.4	●
	FMB40C-150-S	A	40	89	-	150	27	SXM40-S	8.6	●
	FMB40C-200-S	A	40	89	-	200	27	SXM40-S	11.8	○
	FMB60C-75-S	B	60	129	101.6	75	38	SCAM160450-S(4)	8	●

●标准库存Stock ○需预定Available upon Order

三面刃铣刀刀柄  
Solting Cutter Holders

SC

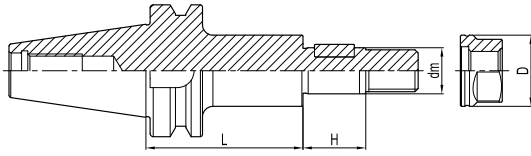

订货号 Ordering Code		尺寸 Dimension (mm)				垫圈 Washer	重量 Weight(kg)	库存 Stock
		dm	D	L	H			
BT40-	SC22-75-S	22	34	75	30	SD22-S	1.7	○
	SC22-120-S	22	34	120	30	SD22-S	2.1	○
	SC27-75-S	27	40	75	30	SD27-S	2	○
	SC27-120-S	27	40	120	30	SD27-S	2.5	○
	SC32-90-S	32	46	90	30	SD32-S	2.6	○
BT50-	SC22-90-S	22	34	90	30	SD22-S	4.4	○
	SC22-135-S	22	34	135	30	SD22-S	4.6	○
	SC27-90-S	27	40	90	30	SD27-S	4.7	○
	SC27-135-S	27	40	135	30	SD27-S	5.2	○
	SC32-90-S	32	46	90	30	SD32-S	5	○
	SC32-135-S	32	46	135	30	SD32-S	5.7	○
	SC40-90-S	40	55	90	30	SD40-S	6	○
	SC40-135-S	40	55	135	30	SD40-S	6.6	○
	SC50-90-S	50	69	90	30	SD50-S	7.2	○
SC50-135-S	50	69	135	30	SD50-S	8.6	○	

●标准库存Stock ○需预定Available upon Order

一体式微补偿攻牙刀柄  
Tapping Chuck

V

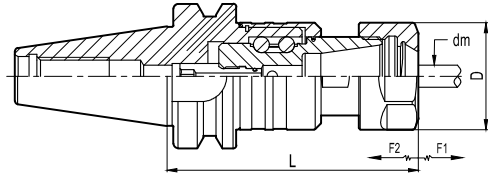

订货号 Ordering Code	适用丝锥 Apply Taps	尺寸 Dimension (mm)					螺母 Nuts	卡簧 Collets	库存 Stock
		dm	D	L	F1	F2			
BT30-V20-80-S	M4~M12 (No.8~7/16)	3~10	34	80	0.5	0.5	ER20-A-S	ER20	●
BT40-V20-85-S		3~10	34	85	0.5	0.5	ER20-A-S	ER20	●
BT50-V20-100-S		3~10	34	100	0.5	0.5	ER20-A-S	ER20	●
BT40-V32-100-S	M4~M20 (No.8~3/4)	3~16	50	100	0.5	0.5	ER32-UM/RD-S	ER32	●
BT50-V32-115-S		3~16	50	115	0.5	0.5	ER32-UM/RD-S	ER32	●

注：筒夹和扳手需单独订购

Notice: Collets and wrenches shall be ordered separately.

●标准库存Stock ○需预定Available upon Order



一体式微补偿攻牙刀柄  
Tapping Chuck

V

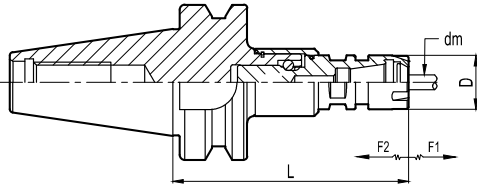

订货号 Ordering Code	适用丝锥 Apply Taps	尺寸 Dimension (mm)					螺母 Nuts	卡簧 Collets	库存 Stock
		dm	D	L	F1	F2			
BT30-V11-70-S	M1-M7	2.5-7	16	70	0.2	0.2	ER11-M-S	ER11	○

注：筒夹和扳手需单独订购

Notice: Collets and wrenches shall be ordered separately.

●标准库存 Stock ○需预定 Available upon Order

TOOLING SYSTEM



**HSK 工具系统**

HSK TOOLING SYSTEM

液压刀柄  
Hydraulic Chuck

# GHP

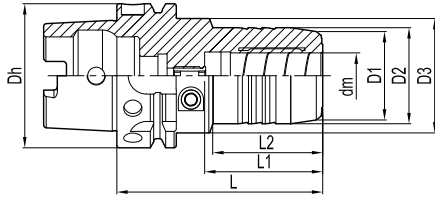

订货号 Ordering Code		尺寸 Dimension (mm)								筒夹 Collets	重量 Weight(kg)	库存 Stock
		Dh	dm	D1	D2	D3	L	L1	L2			
HSK40A-	GHP06-70-S	40	6	22	26	34	70	37	36	-	0.4	○
	GHP08-70-S	40	8	24	28	50	70	37	36/24	-	0.4	○
	GHP10-75-S	40	10	26	30	50	75	41	22	-	0.5	○
	GHP12-85-S	40	12	28	32	50	85	46	30	OD12	0.6	○
HSK50A-	GHP06-75-S	50	6	22	26	42	75	37	28	-	0.7	○
	GHP08-75-S	50	8	24	28	42	75	37	28	-	0.7	○
	GHP10-85-S	50	10	26	30	42	85	41	43	-	0.8	○
	GHP12-85-S	50	12	28	32	42	85	46	44	OD12	0.8	○
	GHP14-85-S	50	14	30	34	56	85	46	28.5	-	0.9	○
	GHP16-90-S	50	16	34	38	56	90	49	28.5	-	1	○
	GHP18-90-S	50	18	36	40	53	90	51	30	-	1.1	○
	GHP20-90-S	50	20	38	42	59.5	90	51	29	OD20	1.1	○
HSK63A-	GHP06-70-S	63	6	22	26	50	70	37	24	-	1	○
	GHP08-70-S	63	8	24	28	50	70	37	25	-	1	●
	GHP10-80-S	63	10	26	30	50	80	41	35	-	1.1	●
	GHP12-85-S	63	12	28	32	50	85	46	40	OD12	1.1	●
	GHP14-85-S	63	14	30	34	50	85	46	40	-	1.1	○
	GHP16-90-S	63	16	34	38	50	90	49	46	-	1.2	●
	GHP18-90-S	63	18	36	40	50	90	49	47	-	1.2	○
	GHP20-90-S	63	20	38	42	50	90	51	48	OD20	1.2	●
	GHP25-120-S	63	25	53	57	63	120	57	59	-	2.2	●
GHP32-125-S	63	32	60	64	75	125	61	63	OD32	2.6	●	
HSK100A-	GHP06-75-S	100	6	22	26	50	75	37	26	-	2.3	○
	GHP08-75-S	100	8	24	28	50	75	37	26	-	2.4	○
	GHP10-90-S	100	10	26	30	50	90	41	42	-	2.4	○
	GHP12-95-S	100	12	28	32	50	95	46	47	OD12	2.5	○
	GHP14-95-S	100	14	30	34	50	95	46	47.6	-	2.5	○
	GHP16-100-S	100	16	34	38	50	100	49	53	-	2.6	●
	GHP18-100-S	100	18	36	40	50	100	49	53	-	2.6	○
	GHP20-105-S	100	20	38	42	50	105	51	59	OD20	2.7	●
	GHP25-110-S	100	25	53	57	63	110	57	62	-	3.4	○
	GHP32-110-S	100	32	60	64	75	110	61	62	OD32	3.7	●

注：筒夹和扳手需单独订购

Notice: Collets and Wrenches shall be ordered separately.

●标准库存Stock ○需预定Available upon Order

附件Accessories	dm=6	dm=8	dm=10	dm=12	dm=16	dm=20	dm=25	dm=32
扳手Hex Wrench	TH05T-L-S						TH06T-L-S	

热装刀柄  
Shrink Fit Holder

SF

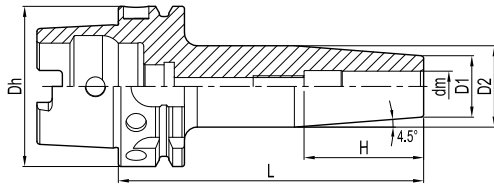

柄径公差  
h6

订货号 Ordering Code	尺寸 Dimension (mm)						重量 Weight(kg)	库存 Stock	
	Dh	dm	D1	D2	L	H			
HSK50A-	SF03-60-S	50	3	10	-	60	-	0.5	○
	SF04-60-S	50	4	10	-	60	-	0.5	○
	SF05-60-S	50	5	10	-	60	-	0.5	○
	SF06-80-S	50	6	21	27	80	36	0.6	○
	SF08-80-S	50	8	21	27	80	36	0.6	○
	SF10-85-S	50	10	24	32	85	42	0.7	○
	SF12-90-S	50	12	24	32	90	47	0.7	○
HSK63A-	SF16-95-S	50	16	27	34	95	47	0.7	○
	SF03-80-S	63	3	10	-	80	-	0.7	○
	SF04-80-S	63	4	10	-	80	-	0.7	●
	SF05-80-S	63	5	10	-	80	-	0.7	○
	SF06-80-S	63	6	21	27	80	36	0.8	○
	SF06-120-S	63	6	21	27	120	36	0.9	○
	SF06-160-S	63	6	21	32	160	36	1.2	○
	SF08-80-S	63	8	21	27	80	36	0.6	●
	SF08-120-S	63	8	21	27	120	36	0.9	●
	SF08-160-S	63	8	21	32	160	36	1.2	●
	SF10-85-S	63	10	24	32	85	42	0.9	●
	SF10-120-S	63	10	24	32	120	42	0.8	●
	SF10-160-S	63	10	24	34	160	42	1.1	●
	SF12-90-S	63	12	24	32	90	47	0.9	●
	SF12-120-S	63	12	24	32	120	47	1	●
	SF12-160-S	63	12	24	34	160	47	1.3	○
	SF14-90-S	63	14	27	34	90	47	1	●
	SF14-120-S	63	14	27	34	120	47	1.1	○
	SF14-160-S	63	14	27	42	160	47	1.5	○
	SF16-95-S	63	16	27	34	95	50	0.9	●
SF16-120-S	63	16	27	34	120	50	1	●	
SF16-160-S	63	16	27	42	160	50	1.5	○	
SF18-95-S	63	18	33	42	95	50	1.2	●	
SF18-120-S	63	18	33	42	120	50	1.3	○	

●标准库存Stock ○需预定Available upon Order

热装刀柄  
Shrink Fit Holder

SF

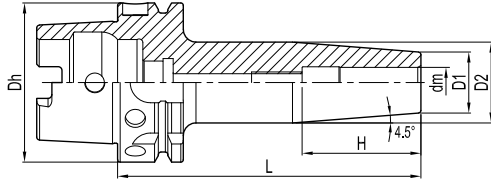

柄径公差  
h6

订货号 Ordering Code	尺寸 Dimension (mm)						重量 Weight(kg)	库存 Stock	
	Dh	dm	D1	D2	L	H			
HSK63A-	SF18-160-S	63	18	33	51	160	50	1.9	○
	SF20-100-S	63	20	33	42	100	52	0.9	●
	SF20-120-S	63	20	33	42	120	52	1.2	○
	SF20-160-S	63	20	33	51	160	52	1.7	○
	SF25-115-S	63	25	44	53	115	58	1.5	●
	SF25-130-S	63	25	44	53	130	58	1.4	○
	SF25-160-S	63	25	44	53	160	58	1.9	○
	SF32-120-S	63	32	44	53	120	58	1.3	○
	SF32-160-S	63	32	44	53	160	58	2.3	○
HSK100A-	SF06-85-S	100	6	21	27	85	36	2.2	○
	SF06-120-S	100	6	21	27	120	36	2.3	○
	SF06-160-S	100	6	21	32	160	36	2.6	○
	SF08-85-S	100	8	21	27	85	36	2	○
	SF08-120-S	100	8	21	27	120	36	2.3	●
	SF08-160-S	100	8	21	32	160	36	2.6	○
	SF10-90-S	100	10	24	32	90	42	2.3	●
	SF10-120-S	100	10	24	32	120	42	2.2	○
	SF10-160-S	100	10	24	34	160	42	2.5	○
	SF12-95-S	100	12	24	32	95	47	2.3	●
	SF12-120-S	100	12	24	32	120	47	2.4	○
	SF12-160-S	100	12	24	34	160	47	2.7	○
	SF14-95-S	100	14	27	34	95	47	2.4	○
	SF14-120-S	100	14	27	34	120	47	2.5	○
	SF14-160-S	100	14	27	42	160	47	2.9	○
	SF16-100-S	100	16	27	34	100	50	2.3	●
	SF16-120-S	100	16	27	34	120	50	2.4	○
	SF16-160-S	100	16	27	42	160	50	2.9	○
	SF18-100-S	100	18	33	42	100	50	2.6	○
	SF18-120-S	100	18	33	42	120	50	2.7	○
	SF18-160-S	100	18	33	51	160	50	3.3	○
	SF20-105-S	100	20	33	42	105	52	2.4	○

●标准库存Stock ○需预定Available upon Order

热装刀柄  
Shrink Fit Holder

# SF

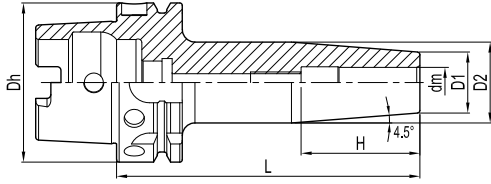

柄径公差  
h6

订货号 Ordering Code	尺寸 Dimension (mm)						重量 Weight(kg)	库存 Stock	
	Dh	dm	D1	D2	L	H			
HSK100A-	SF20-120-S	100	20	33	42	120	52	2.7	○
	SF20-160-S	100	20	33	51	160	52	3.2	○
	SF25-115-S	100	25	44	53	115	58	2.9	○
	SF25-130-S	100	25	44	53	130	58	2.8	○
	SF25-160-S	100	25	44	60	160	58	3.3	○
	SF32-120-S	100	32	44	53	120	58	2.7	○
	SF32-160-S	100	32	44	60	160	58	3.7	○

●标准库存Stock ○需预定Available upon Order

特点  
Feature

动平衡设定 Balanced	3D处径向跳动 Runout (X3D)
G2.5; 25,000 rpm	< 0.003 mm

热装刀柄  
Shrink Fit Holder

SF

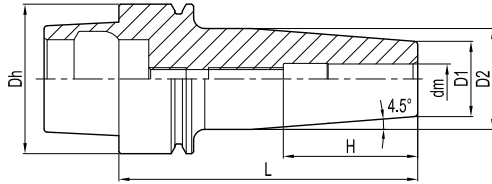

柄径公差  
h6

订货号 Ordering Code	尺寸 Dimension (mm)						重量 Weight(kg)	库存 Stock	
	Dh	dm	D1	D2	L	H			
HSK40E-	SF03-60-S	40	3	10	-	60	-	0.4	○
	SF04-60-S	40	4	10	-	60	-	0.4	○
	SF05-60-S	40	5	10	-	60	-	0.4	○
	SF06-60-S	40	6	21	27	60	36	0.4	○
	SF08-80-S	40	8	21	27	80	36	0.4	○
	SF10-80-S	40	10	24	32	80	42	0.5	○
	SF12-90-S	40	12	24	32	90	47	0.5	○
	SF14-90-S	40	14	27	34	90	47	0.6	○
	SF16-90-S	40	16	27	34	90	50	0.5	○

●标准库存Stock ○需预定Available upon Order

特点  
Feature

动平衡设定 Balanced	3D处径向跳动 Runout (X3D)
G2.5; 25,000 rpm	<0.003 mm

高速精密筒夹刀柄  
High Precision Collet Chuck

# SD

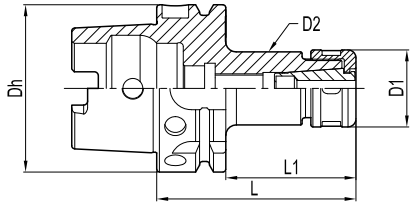

订货号 Ordering Code	尺寸 Dimension (mm)					筒夹 Collets	重量 Weight(kg)	库存 Stock	
	Dh	D1	D2	L	L1				
HSK40A-	SD06-60-S	40	19.5	20	60	40	SD06	0.3	○
	SD10-75-S	40	27	27.5	75	55	SD10	0.4	○
HSK50A-	SD06-60-S	50	19.5	20	60	34	SD06	0.4	○
	SD06-80-S	50	19.5	20	80	54	SD06	0.5	○
	SD10-75-S	50	27	27.5	75	49	SD10	0.5	○
	SD10-100-S	50	27	27.5	100	74	SD10	0.6	○
	SD16-80-S	50	40	40.5	80	54	SD16	0.6	○
	SD16-100-S	50	40	40.5	100	74	SD16	0.9	○
HSK63A-	SD20-100-S	50	48	48.5	100	74	SD20	1.2	○
	SD06-80-S	63	19.5	20	80	54	SD06	0.8	○
	SD06-100-S	63	19.5	20	100	74	SD06	0.9	○
	SD10-75-S	63	27	27.5	75	49	SD10	0.8	○
	SD10-100-S	63	27	27.5	100	74	SD10	1.1	○
	SD16-80-S	63	40	40.5	80	54	SD16	1.1	○
	SD16-100-S	63	40	40.5	100	74	SD16	1.3	○
	SD16-120-S	63	40	40.5	120	94	SD16	1.6	○
HSK100A-	SD20-100-S	63	48	48.5	100	74	SD20	1.5	○
	SD20-120-S	63	48	48.5	120	94	SD20	1.8	○
	SD10-105-S	100	27	27.5	105	76	SD10	2.6	○
	SD10-135-S	100	27	27.5	135	106	SD10	3	○
	SD16-105-S	100	40	40.5	105	76	SD16	2.7	○
	SD16-135-S	100	40	40.5	135	106	SD16	3.3	○
	SD20-120-S	100	48	48.5	120	91	SD20	3.1	○
	SD20-150-S	100	48	48.5	150	121	SD20	3.5	○

注：筒夹与扳手需单独另购

Notice: Collets and wrenches shall be ordered separately.

●标准库存Stock ○需预定Available upon Order



ER弹性筒夹刀柄  
Spring Collet Chuck

# ER

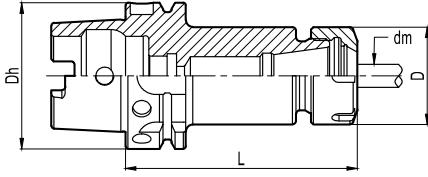

订货号 Ordering Code		尺寸 Dimension (mm)				重量 Weight(kg)	库存 Stock
		Dh	dm	D	L		
HSK40A-	ER20-80-S	40	1.0~13	34	80	0.5	○
	ER25-80-S	40	1.0~16	42	80	0.6	○
	ER32-100-S	40	2.0~20	50	100	1	○
HSK50A-	ER16-75-S	50	0.5~10	28	75	0.6	○
	ER16-100-S	50	0.5~10	28	100	0.7	○
	ER20-75-S	50	1.0~13	34	75	0.7	○
	ER20-100-S	50	1.0~13	34	100	0.8	○
	ER25-80-S	50	1.0~16	42	80	0.8	○
	ER25-100-S	50	1.0~16	42	100	1	○
	ER25-135-S	50	1.0~16	42	135	1.1	○
	ER32-100-S	50	2.0~20	50	100	1.2	○
	ER32-135-S	50	2.0~20	50	135	1.5	○
HSK63A-	ER32-160-S	50	2.0~20	50	160	2.1	○
	ER11-75-S	63	0.5~7	19	75	0.7	○
	ER16-80-S	63	0.5~10	28	80	0.8	○
	ER16-100-S	63	0.5~10	28	100	0.9	●
	ER16-120-S	63	0.5~10	28	120	1	○
	ER16-160-S	63	0.5~10	28	160	1.2	●
	ER20-80-S	63	1.0~13	34	80	0.9	○
	ER20-100-S	63	1.0~13	34	100	1	●
	ER20-120-S	63	1.0~13	34	120	1.2	○
	ER20-160-S	63	1.0~13	34	160	1.4	○
	ER25-80-S	63	1.0~16	42	80	1	●
	ER25-100-S	63	1.0~16	42	100	1.2	●
	ER25-120-S	63	1.0~16	42	120	1.4	○
	ER25-150-S	63	1.0~16	42	150	1.7	○
	ER32-80-S	63	2.0~20	50	80	1.2	●
	ER32-100-S	63	2.0~20	50	100	1.4	●
	ER32-120-S	63	2.0~20	50	120	1.7	○
	ER32-160-S	63	2.0~20	50	160	2.3	○
ER40-80-S	63	3.0~26	63	80	1.2	○	

●标准库存Stock ○需预定Available upon Order

ER弹性筒夹刀柄  
Spring Collet Chuck

# ER

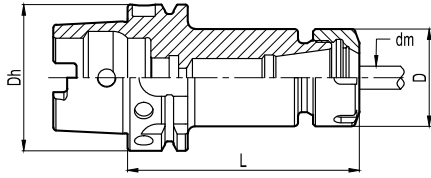

订货号 Ordering Code		尺寸 Dimension (mm)				重量 Weight(kg)	库存 Stock
		Dh	dm	D	L		
HSK63A-	ER40-100-S	63	3.0~26	63	100	1.5	○
	ER40-120-S	63	3.0~26	63	120	1.7	○
	ER40-160-S	63	3.0~26	63	160	2.3	○
HSK100A-	ER16-100-S	100	0.5~10	28	100	2.3	○
	ER16-160-S	100	0.5~10	28	160	2.5	○
	ER20-100-S	100	1.0~13	34	100	2.4	○
	ER20-160-S	100	1.0~13	34	160	2.7	○
	ER25-100-S	100	1.0~16	42	100	2.5	●
	ER25-160-S	100	1.0~16	42	160	3.1	○
	ER25-200-S	100	1.0~16	42	200	3.5	○
	ER32-100-S	100	2.0~20	50	100	2.7	●
	ER32-160-S	100	2.0~20	50	160	3.6	●
	ER32-200-S	100	2.0~20	50	200	4.1	○
	ER40-100-S	100	3.0~26	63	100	3.1	○
	ER40-120-S	100	3.0~26	63	120	3.5	○
	ER40-160-S	100	3.0~26	63	160	4.4	○
	ER40-200-S	100	3.0~26	63	200	5.2	○

注：筒夹与扳手需单独另购

Notice: Collets and wrenches shall be ordered separately.

●标准库存Stock ○需预定Available upon Order

强力筒夹刀柄  
Power Milling Chuck For Heavy Duty

# GLC

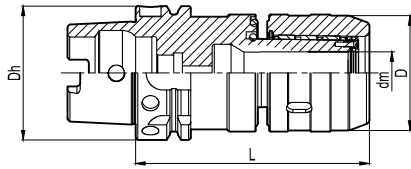

订货号 Ordering Code	范围 Range(mm)	尺寸 Dimension (mm)				筒夹 Collets	重量 Weight(kg)	库存 Stock
		Dh	dm	D	L			
HSK63A-GLC20-105-S	6-20	63	20	52	105	GC20	2.3	○
HSK63A-GLC25-110-S	6-25	63	25	62	110	GC25	2.5	○
HSK63A-GLC32-115-S	6-32	63	32	72	115	GC32	2.7	●
HSK100A-GLC20-110-S	6-20	100	20	52	110	GC20	2.7	○
HSK100A-GLC25-115-S	6-25	100	25	62	115	GC25	2.8	○
HSK100A-GLC32-120-S	6-32	100	32	72	120	GC32	2.9	○
HSK100A-GLC42-120-S	6-42	100	42	87	120	GC42	3.1	○

●标准库存Stock ○需预定Available upon Order

注：筒夹与扳手需单独另购

Notice: Collets and wrenches shall be ordered separately.

侧固式刀柄  
Side-lock Holder

# GLN

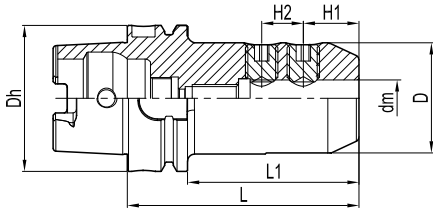

订货号 Ordering Code	尺寸 Dimension (mm)							侧固螺钉 Screws	重量 Weight(kg)	库存 Stock	
	Dh	dm	D	L	L1	H1	H2				
HSK63A-	GLN16-80-S	63	16	48	80	54	24	-	STCM140160-S	1.2	○
	GLN20-80-S	63	20	52	80	54	25	-	STCM160160-S	1.3	○
	GLN25-110-S	63	25	65	110	84	24	25	STCM180200-S	2.24	○
	GLN32-110-S	63	32	72	110	84	24	28	STCM200200-S	2.24	○
HSK100A-	GLN16-100-S	100	16	48	100	71	24	-	STCM140160-S	2.82	○
	GLN20-100-S	100	20	52	100	71	25	-	STCM160160-S	2.93	○
	GLN25-100-S	100	25	65	100	81	24	25	STCM180200-S	3.5	○
	GLN32-100-S	100	32	72	100	71	24	28	STCM200200-S	3.7	○

注：扳手需单独订购。

Notice: wrenches shall be ordered separately.

●标准库存Stock ○需预定Available upon Order

侧固式刀柄 (2°)  
Side-lock Holder (2°)

# GLNB

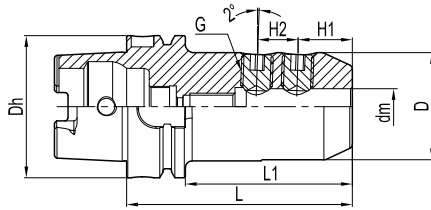

订货号 Ordering Code	尺寸 Dimension (mm)							侧固螺钉 Screws	重量 Weight(kg)	库存 Stock	
	Dh	dm	D	L	L1	H1	H2				
HSK63A-	GLNB16-100-S	63	16	48	100	74	24	-	STCM140160-S	1.51	○
	GLNB20-100-S	63	20	52	100	74	25	-	STCM160160-S	1.65	○
	GLNB25-110-S	63	25	65	110	84	24	65.5	STCM180200-S	2.23	○
	GLNB32-110-S	63	32	72	110	84	24	65.5	STCM200200-S	2.43	○
HSK100A-	GLNB16-100-S	100	16	48	100	71	24	-	STCM140160-S	2.88	○
	GLNB20-110-S	100	20	52	110	81	25	-	STCM160160-S	3.1	○
	GLNB25-120-S	100	25	65	120	91	24	-	STCM180200-S	3.91	○
	GLNB32-120-S	100	32	72	120	91	24	-	STCM200200-S	4.32	○

注：扳手需单独订购。

Notice: wrenches shall be ordered separately.

●标准库存Stock ○需预定Available upon Order

有扁尾莫氏圆锥孔刀柄  
Morse Taper Holder with Tang

# MTA

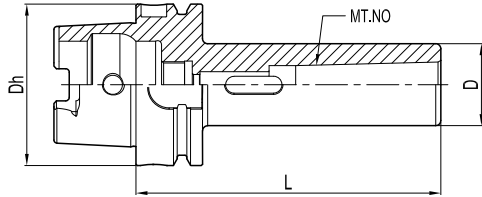

订货号 Ordering Code	MT	尺寸 Dimension (mm)			重量 Weight(kg)	库存 Stock	
		Dh	D	L			
HSK63A-	MTA1-100-S	1	63	25	100	0.88	○
	MTA2-120-S	2	63	32	120	1.09	○
	MTA3-140-S	3	63	40	140	1.45	○
	MTA4-160-S	4	63	48	160	1.89	○
HSK100A-	MTA1-110-S	1	100	25	110	2.23	○
	MTA2-120-S	2	100	32	120	2.39	○
	MTA3-150-S	3	100	40	150	2.83	○
	MTA4-170-S	4	100	48	170	3.31	○
	MTA5-200-S	5	100	63	200	4.6	○

注：扳手需单独订购。  
Notice: wrenches shall be ordered separately.

●标准库存Stock ○需预定Available upon Order

面铣刀刀柄  
Face Mill Holder

# FMB

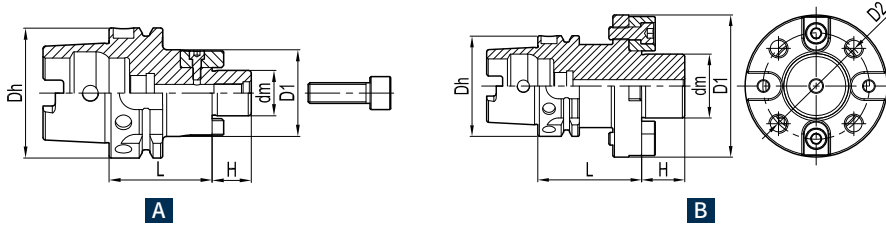

订货号 Ordering Code	图示 Figure	尺寸 Dimension (mm)						压紧螺钉 Screw	重量 Weight(kg)	库存 Stock	
		Dh	dm	D1	D2	L	H				
HSK63A-	FMB16C-50-S	A	63	16	34	-	50	17	SCAM080300-S	0.8	○
	FMB16C-100-S	A	63	16	34	-	100	17	SCAM080300-S	1.2	○
	FMB22C-50-S	A	63	22	42	-	50	19	SCAM100300-S	1	○
	FMB22C-100-S	A	63	22	42	-	100	19	SCAM100300-S	1.5	○
	FMB27C-60-S	A	63	27	60	-	60	21	SXM27-S	1.4	●
	FMB27C-100-S	A	63	27	60	-	100	21	SXM27-S	2.1	○
	FMB32C-60-S	A	63	32	78	-	60	24	SXM32-S	1.8	○
	FMB32C-100-S	A	63	32	78	-	100	24	SXM32-S	2.4	○
HSK100A-	FMB40C-60-S	A	63	40	89	-	60	27	SXM40-S	2.3	○
	FMB22C-50-S	A	100	22	42	-	50	19	SCAM100300-S	2.3	○
	FMB22C-100-S	A	100	22	42	-	100	19	SCAM100300-S	2.8	○
	FMB27C-50-S	A	100	27	60	-	50	21	SXM27-S	2.6	○
	FMB27C-100-S	A	100	27	60	-	100	21	SXM27-S	3.7	○
	FMB32C-50-S	A	100	32	78	-	50	24	SXM32-S	3	○
	FMB32C-100-S	A	100	32	78	-	100	24	SXM32-S	4.9	○
	FMB40C-60-S	A	100	40	89	-	60	27	SXM40-S	3.9	○
	FMB40C-75-S	A	100	40	89	-	75	27	SXM40-S	4.5	○
	FMB40C-100-S	A	100	40	89	-	100	27	SXM40-S	5.4	○
FMB60C-75-S	B	100	40	129	101.6	75	38	SCAM160450-S(4)	6.6	○	

●标准库存Stock ○需预定Available upon Order

三面刃铣刀刀柄  
Solting Cutter Holders

# SC

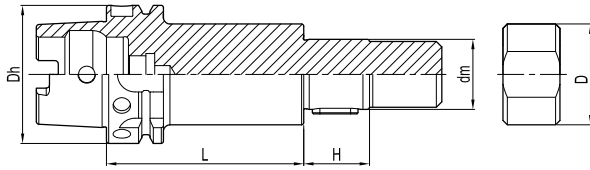

订货号 Ordering Code	尺寸 Dimension (mm)					垫圈 Washer	重量 Weight(kg)	库存 Stock	
	Dh	dm	D	L	H				
HSK63A-	SC13-75-S	63	13	20	75	30	SD13-S	0.9	○
	SC16-90-S	63	16	26	90	30	SD16-S	1.1	○
	SC16-120-S	63	16	26	120	30	SD16-S	1.1	○
	SC22-90-S	63	22	34	90	30	SD22-S	1.5	○
	SC22-135-S	63	22	34	135	30	SD22-S	1.8	○
	SC27-90-S	63	27	40	90	30	SD27-S	1.8	○
	SC27-135-S	63	27	40	135	30	SD27-S	2.3	○
	SC32-90-S	63	32	46	90	30	SD32-S	2.3	○
HSK100A-	SC32-135-S	63	32	46	135	30	SD32-S	2.9	○
	SC13-75-S	100	13	20	75	30	SD13-S	2.2	○
	SC16-90-S	100	16	26	90	30	SD16-S	2.3	○
	SC16-120-S	100	16	26	120	30	SD16-S	2.6	○
	SC22-90-S	100	22	34	90	30	SD22-S	2.9	○
	SC22-135-S	100	22	34	135	30	SD22-S	3.2	○
	SC27-90-S	100	27	40	90	30	SD27-S	3.1	○
	SC27-135-S	100	27	40	135	30	SD27-S	3.6	○
	SC32-90-S	100	32	46	90	30	SD32-S	3.6	○
	SC32-135-S	100	32	46	135	30	SD32-S	4.2	○
	SC40-90-S	100	40	55	90	30	SD40-S	4.4	○
SC40-135-S	100	40	55	135	30	SD40-S	5.2	○	

●标准库存Stock ○需预定Available upon Order



一体式微补偿攻牙刀柄  
Tapping Chuck

V

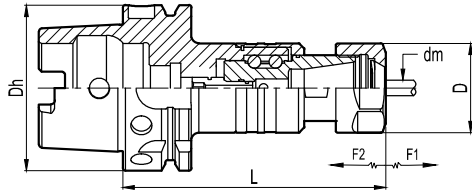

订货号 Ordering Code	适用丝锥 Apply Taps	尺寸 Dimension (mm)						螺帽 Nuts	筒夹 Collets	库存 Stock
		Dh	dm	D	L	F1	F2			
HSK63A-V20-100-S	M4~M12 (No.8~7/16)	63	3~10	34	100	0.5	0.5	ER20-A-S	ER20	●
HSK100A-V20-110-S		100	3~10	34	110	0.5	0.5	ER20-A-S	ER20	○
HSK63A-V32-120-S	M4~M20 (No.8~3/4)	63	3~16	50	120	0.5	0.5	ER32-UM/RD-S	ER32	●
HSK100A-V32-130-S		100	3~16	50	130	0.5	0.5	ER32-UM/RD-S	ER32	○

注：筒夹和扳手需单独订购

Notice: Collets and wrenches shall be ordered separately.

●标准库存Stock ○需预定Available upon Order

TOOLING SYSTEM



配件

ACCESSORIES

ER弹性筒夹延长杆  
ER Collet Chucks Extensions

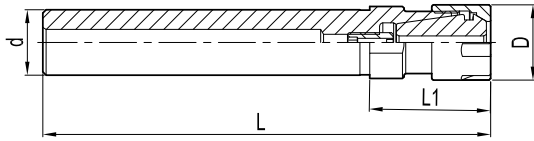

订货号 Ordering Code		尺寸 Dimension (mm)				螺帽 Nuts	筒夹 Collets	重量 Weight(kg)
		D	d	L1	L			
C12-	ER11M-100-S	16	12	25	125	ER11-M-S	ER11	0.12
	ER11M-150-S	16	12	25	175	ER11-M-S	ER11	0.14
C16-	ER11M-100-S	16	16	25	125	ER11-M-S	ER11	0.14
	ER11M-150-S	16	16	25	175	ER11-M-S	ER11	0.22
	ER16M-100-S	22	16	36	136	ER16-M-S	ER16	0.15
C20-	ER16M-150-S	22	16	36	186	ER16-M-S	ER16	0.21
	ER16M-100-S	22	20	36	136	ER16-M-S	ER16	0.24
	ER16M-150-S	22	20	36	186	ER16-M-S	ER16	0.33
	ER20M-100-S	28	20	42	142	ER20-M-S	ER20	0.23
	ER20M-150-S	28	20	42	192	ER20-M-S	ER20	0.32
	ER20M-200-S	28	20	42	242	ER20-M-S	ER20	0.53
C25-	ER25M-100-S	35	20	50	150	ER25-M-S	ER25	0.55
	ER20M-150-S	28	25	42	192	ER20-M-S	ER20	0.50

注：筒夹和扳手需单独订购

Notice: Collets and wrenches shall be ordered separately.

一体式攻牙刀柄延长杆  
Tapping Chuck Extensions

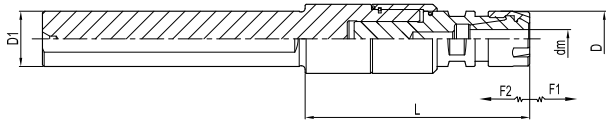

订货号 Ordering Code	适用丝锥 Apply Taps	尺寸 Dimension (mm)						螺帽 Nuts	筒夹 Collets	重量 Weight(kg)
		D	dm	D1	L	F1	F2			
C16-V11-65-S	M1-M7	16	2.5-7.0	16	65	0.2	0.2	ER11-M-S	ER11	0.22

一体式攻牙刀柄延长杆  
Tapping Chuck Extensions

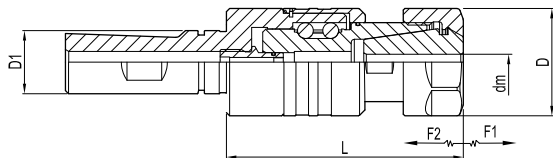

订货号 Ordering Code	适用丝锥 Apply Taps	尺寸 Dimension (mm)						螺帽 Nuts	筒夹 Collets	重量 Weight(kg)
		D	dm	D1	L	F1	F2			
C20-V20-85-S	M4-M12 (No.8~7/16)	34	3~10	20	85	0.5	0.5	ER20-A-S	ER20	0.35
C25-V20-85-S		34	3~10	25	85	0.5	0.5	ER20-A-S	ER20	0.45
C25-V32-110-S	M4-M20 (No.8~3/4)	50	3~10	25	110	0.5	0.5	ER32-UM/RD-S	ER32	0.6

热装刀柄延长杆  
Shrink Fit Extensions

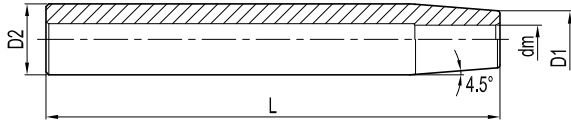

柄径公差  
h6



订货号 Ordering Code		尺寸 Dimension (mm)				重量 Weight(kg)
		dm	D1	D2	L	
C12-	SF3-160-S	3	8	12	160	0.2
	SF4-160-S	4	8	12	160	0.21
C16-	SF3-160-S	3	10	16	160	0.22
	SF4-160-S	4	10	16	160	0.23
	SF5-160-S	5	10	16	160	0.24
	SF6-160-S	6	10	16	160	0.25
C20-	SF5-160-S	5	14	20	160	0.4
	SF6-160-S	6	14	20	160	0.42
	SF8-160-S	8	14	20	160	0.44
C25-	SF8-160-S	8	20	25	160	0.6
	SF10-160-S	10	20	25	160	0.62
	SF12-160-S	12	20	25	160	0.65
C32-	SF10-160-S	10	27	32	160	0.78
	SF12-160-S	12	27	32	160	0.81
	SF16-160-S	16	27	32	160	0.83
	SF20-160-S	20	27	32	160	0.85

SD精密筒夹  
SD Precision Collet

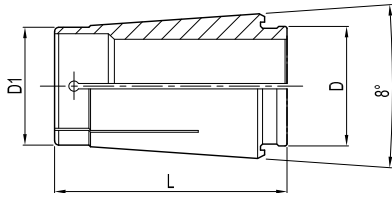

订货号 Ordering Code		尺寸 Dimension (mm)		
		D	D1	L
SD	6	9	7.5	25
	10	13	11.9	30.5
	16	20.3	18.7	45
	20	24	23	50
	25	29.3	28.7	57

SD精密筒夹  
SD Precision Collet

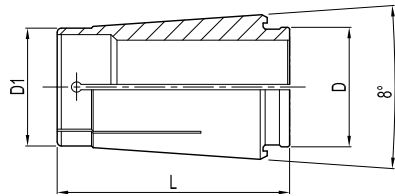

SD6-9PCS		
订货号 Ordering Code	范围 Range(mm)	
SD6-	2UP-S	1.8-2.0
	2.5UP-S	2.3-2.5
	3UP-S	2.8-3.0
	3.5UP-S	3.0-3.5
	4UP-S	3.5-4.0
	4.5UP-S	4.0-4.5
	5UP-S	4.5-5.0
	5.5UP-S	5.0-5.5
6UP-S	5.5-6.0	

SD10-16PCS		
订货号 Ordering Code	范围 Range(mm)	
SD10-	2UP-S	1.75-2.0
	3UP-S	2.75-3.0
	3.5UP-S	3.0-3.5
	4UP-S	3.5-4.0
	4.5UP-S	4.0-4.5
	5UP-S	4.5-5.0
	5.5UP-S	5.0-5.5
	6UP-S	5.5-6.0
	6.5UP-S	6.0-6.5
	7UP-S	6.5-7.0
	7.5UP-S	7.0-7.5
	8UP-S	7.5-8.0
	8.5UP-S	8.0-8.5
	9UP-S	8.5-9.0
	9.5UP-S	9.0-9.5
	10UP-S	9.5-10.0

SD16-27PCS		
订货号 Ordering Code	范围 Range(mm)	
SD16-	3UP-S	2.75-3.0
	3.5UP-S	3.0-3.5
	4UP-S	3.5-4.0
	4.5UP-S	4.0-4.5
	5UP-S	4.5-5.0
	5.5UP-S	5.0-5.5
	6UP-S	5.5-6.0
	6.5UP-S	6.0-6.5
	7UP-S	6.5-7.0
	7.5UP-S	7.0-7.5
	8UP-S	7.5-8.0
	8.5UP-S	8.0-8.5
	9UP-S	8.5-9.0
	9.5UP-S	9.0-9.5
	10UP-S	9.5-10.0
	10.5UP-S	10.0-10.5
	11UP-S	10.5-11.0
	11.5UP-S	11.0-11.5
	12UP-S	11.5-12.0
	12.5UP-S	12.0-12.5
	13UP-S	12.5-13.0
	13.5UP-S	13.0-13.5
	14UP-S	13.5-14.0
	14.5UP-S	14.0-14.5
	15UP-S	14.5-15.0
	15.5UP-S	15.0-15.5
	16UP-S	15.5-16.0

SD20-34PCS		
订货号 Ordering Code	范围 Range(mm)	
SD20-	3.5UP-S	3.0-3.5
	4UP-S	3.5-4.0
	4.5UP-S	4.0-4.5
	5UP-S	4.5-5.0
	5.5UP-S	5.0-5.5
	6UP-S	5.5-6.0
	6.5UP-S	6.0-6.5
	7UP-S	6.5-7.0
	7.5UP-S	7.0-7.5
	8UP-S	7.5-8.0
	8.5UP-S	8.0-8.5
	9UP-S	8.5-9.0
	9.5UP-S	9.0-9.5
	10UP-S	9.5-10.0
	10.5UP-S	10.0-10.5
	11UP-S	10.5-11.0
	11.5UP-S	11.0-11.5
	12UP-S	11.5-12.0
	12.5UP-S	12.0-12.5
	13UP-S	12.5-13.0
	13.5UP-S	13.0-13.5
	14UP-S	13.5-14.0
	14.5UP-S	14.0-14.5
	15UP-S	14.5-15.0
	15.5UP-S	15.0-15.5
	16UP-S	15.5-16.0
	16.5UP-S	16.0-16.5
	17UP-S	16.5-17.0
	17.5UP-S	17.0-17.5
	18UP-S	17.5-18.0
	18.5UP-S	18.0-18.5
	19UP-S	18.5-19.0
	19.5UP-S	19.0-19.5
	20UP-S	19.5-20.0

SD精密筒夹  
SD Precision Collet

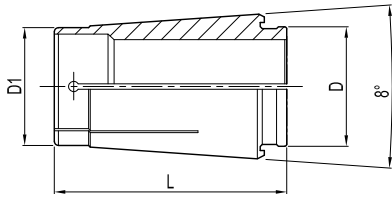

SD25-44PCS		
订货号 Ordering Code	范围 Range(mm)	
SD25-	3.5UP-S	3.0-3.5
	4UP-S	3.5-4.0
	4.5UP-S	4.0-4.5
	5UP-S	4.5-5.0
	5.5UP-S	5.0-5.5
	6UP-S	5.5-6.0
	6.5UP-S	6.0-6.5
	7UP-S	6.5-7.0
	7.5UP-S	7.0-7.5
	8UP-S	7.5-8.0
	8.5UP-S	8.0-8.5
	9UP-S	8.5-9.0
	9.5UP-S	9.0-9.5
	10UP-S	9.5-10.0
	10.5UP-S	10.0-10.5
	11UP-S	10.5-11.0
	11.5UP-S	11.0-11.5
	12UP-S	11.5-12.0
	12.5UP-S	12.0-12.5
	13UP-S	12.5-13.0
13.5UP-S	13.0-13.5	
14UP-S	13.5-14.0	
14.5UP-S	14.0-14.5	

SD25-44PCS		
订货号 Ordering Code	范围 Range(mm)	
SD25-	15UP-S	14.5-15.0
	15.5UP-S	15.0-15.5
	16UP-S	15.5-16.0
	16.5UP-S	16.0-16.5
	17UP-S	16.5-17.0
	17.5UP-S	17.0-17.5
	18UP-S	17.5-18.0
	18.5UP-S	18.0-18.5
	19UP-S	18.5-19.0
	19.5UP-S	19.0-19.5
	20UP-S	19.5-20.0
	20.5UP-S	20.0-20.5
	21UP-S	20.5-21.0
	21.5UP-S	21.0-21.5
	22UP-S	21.5-22.0
	22.5UP-S	22.0-22.5
	23UP-S	22.5-23.0
	23.5UP-S	23.0-23.5
	24UP-S	23.5-24.0
	24.5UP-S	24.0-24.5
25UP-S	24.5-25.0	
25.4UP-S	25.0-25.4	

注：上述筒夹适用于SD高速精密筒夹刀柄。  
Note: These Collets are suitable for SD High Precision Holder.



ER弹性筒夹  
ER Collet

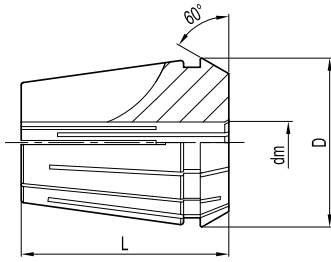

订货号 Ordering Code		尺寸 Dimension (mm)		重量 Weight(kg)
		D	L	
ER	11	11.50	18	0.01
	16	17.00	27.5	0.03
	20	21.00	31.5	0.04
	25	26	34	0.06
	32	33	40	0.10
	40	41	46	0.25

特点  
Feature

型号 Model	夹持范围 Chucking range
ER11	0.5mm
ER16/20/25/32/40	1mm

使用说明  
Spring Collet Precision

型号 Grade	范围 Range(mm)
A级	≤0.01 mm
UP级	≤0.005 mm

注：另有止水内冷型ER筒夹可选配。例：ER16-5C  
Note: ER Collet with internal cooling is available. Example: ER16-5C

ER筒夹命名规则  
Naming rule

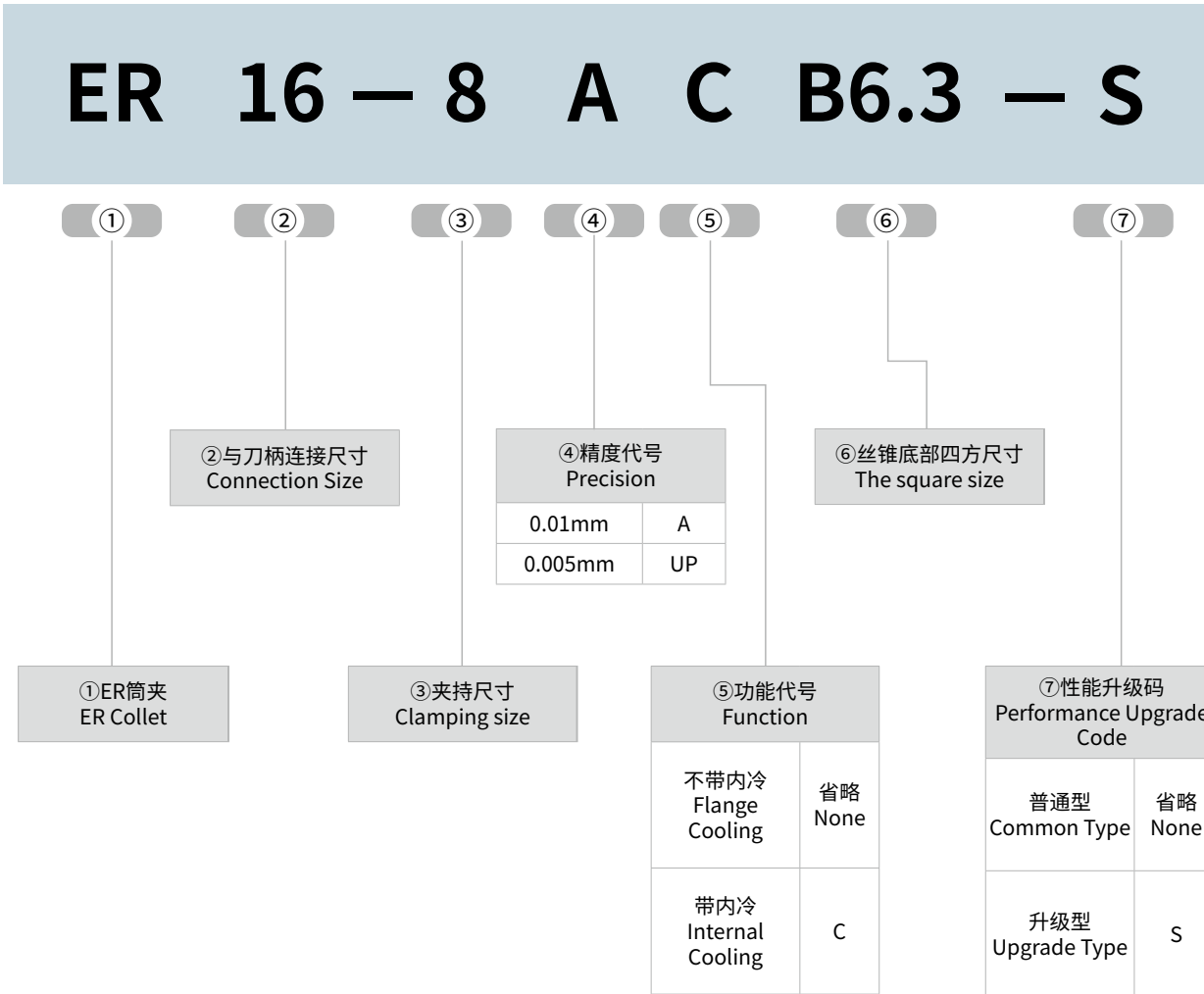

ER弹性筒夹  
ER Collet

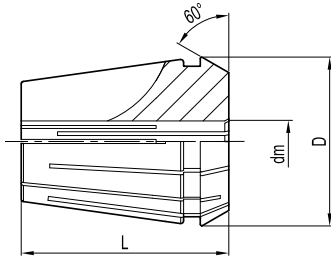

ER11-10PCS		
订货号 Ordering Code	范围 Range(mm)	
2.5A-S	2.5-2.0	
3A-S	3.0-2.5	
3.5A-S	3.5-3.0	
4A-S	4.0-3.5	
4.5A-S	4.5-4.0	
5A-S	5.0-4.5	
5.5A-S	5.5-5.0	
6A-S	6.0-5.5	
6.5A-S	6.5-7.0	
7A-S	7.0-6.5	

ER16-8PCS		
订货号 Ordering Code	范围 Range(mm)	
3A-S	3.0-2.0	
4A-S	4.0-3.0	
5A-S	5.0-4.0	
6A-S	6.0-5.0	
7A-S	7.0-6.0	
8A-S	8.0-7.0	
9A-S	9.0-8.0	
10A-S	10-9.0	

ER20-11PCS		
订货号 Ordering Code	范围 Range(mm)	
3A-S	3.0-2.0	
4A-S	4.0-3.0	
5A-S	5.0-4.0	
6A-S	6.0-5.0	
7A-S	7.0-6.0	
8A-S	8.0-7.0	
9A-S	9.0-8.0	
10A-S	10-9.0	
11A-S	11-10	
12A-S	12-11	
13A-S	13-12	

ER25-14PCS		
订货号 Ordering Code	范围 Range(mm)	
3A-S	3.0-2.0	
4A-S	4.0-3.0	
5A-S	5.0-4.0	
6A-S	6.0-5.0	
7A-S	7.0-6.0	
8A-S	8.0-7.0	
9A-S	9.0-8.0	
10A-S	10-9.0	
11A-S	11-10	
12A-S	12-11	
13A-S	13-12	
14A-S	14-13	
15A-S	15-14	
16A-S	16-15	

ER32-18PCS		
订货号 Ordering Code	范围 Range(mm)	
3A-S	3.0-2.0	
4A-S	4.0-3.0	
5A-S	5.0-4.0	
6A-S	6.0-5.0	
7A-S	7.0-6.0	
8A-S	8.0-7.0	
9A-S	9.0-8.0	
10A-S	10-9.0	
11A-S	11-10	
12A-S	12-11	
13A-S	13-12	
14A-S	14-13	
15A-S	15-14	
16A-S	16-15	
17A-S	17-16	
18A-S	18-17	
19A-S	19-18	
20A-S	20-19	

ER40-23PCS		
订货号 Ordering Code	范围 Range(mm)	
4A-S	4.0-3.0	
5A-S	5.0-4.0	
6A-S	6.0-5.0	
7A-S	7.0-6.0	
8A-S	8.0-7.0	
9A-S	9.0-8.0	
10A-S	10-9.0	
11A-S	11-10	
12A-S	12-11	
13A-S	13-12	
14A-S	14-13	
15A-S	15-14	
16A-S	16-15	
17A-S	17-16	
18A-S	18-17	
19A-S	19-18	
20A-S	20-19	
21A-S	21-20	
22A-S	22-21	
23A-S	23-22	
24A-S	24-23	
25A-S	25-24	
26A-S	26-25	

ER攻丝筒夹  
ER Tapping Collet

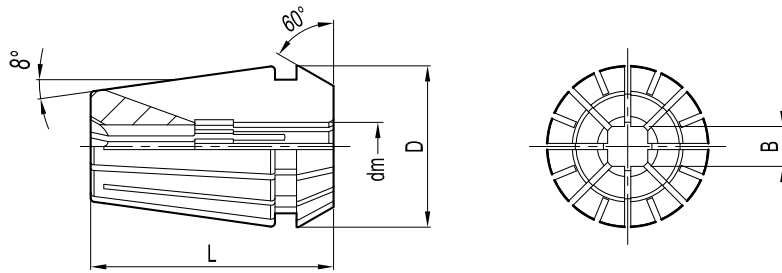

订货号 Ordering Code					尺寸 Dimension (mm)		丝锥标准Taps					
					dm	B	ISO529(1)	ISO529(2)	JIS	DIN371	DIN376	
ER16-					2.24B1.8-S	2.24	1.8	-	M3	-	-	-
ER16-					2.8B2.1-S	2.8	2.1	-	-	-	-	M4
ER16-					3.15B2.5-S	3.15	2.5	M3	M4	-	-	-
ER16-					3.5B2.7-S	3.5	2.7	-	-	-	M3	M5
ER16-	ER20-				4B3.2-S	4	3.2	M4	M5	M3	-	-
ER16-	ER20-	ER25-			4.5B3.55-S	4.5	3.55	-	M6	-	-	-
ER16-	ER20-	ER25-			5B4-S	5	4	M5	-	M4	-	-
ER16-	ER20-	ER25-			5.5B4.5-S	5.5	4.5	-	-	M5、W3/16	-	-
ER16-	ER20-	ER25-			6B4.5-S	6	4.5	-	-	M6、W1/4	-	-
ER16-	ER20-	ER25-			6.2B5-S	6.2	5	-	-	M8	-	-
ER16-	ER20-	ER25-	ER32-		6.3B5-S	6.3	5	M6	M8	-	-	-
ER16-	ER20-	ER25-	ER32-		7B5.5-S	7	5.5	-	-	M10、W3/8	-	M10
ER16-	ER20-	ER25-	ER32-		8B6.3-S	8	6.3	M8	M10	-	-	-
ER16-	ER20-	ER25-	ER32-		8.5B6.5-S	8.5	6.5	-	-	M12	-	-
ER16-	ER20-	ER25-	ER32-		9B7.1-S	9	7.1	-	M12	-	-	M12
ER16-	ER20-	ER25-	ER32-	ER40-	10B8-S	10	8	M10	-	-	M10	-
	ER20-	ER25-	ER32-	ER40-	10.5B8-S	10.5	8	-	-	M14	-	-
	ER20-	ER25-	ER32-	ER40-	11.2B9-S	11.2	9	-	M14	-	-	-
	ER20-	ER25-	ER32-	ER40-	12.5B10-S	12.5	10	-	M16	M16	-	-
		ER25-	ER32-	ER40-	14B11.2-S	14	11.2	-	M18、M20-	M18	-	-
		ER25-	ER32-	ER40-	15B12-S	15	12	-	-	M20-	-	-
			ER32-	ER40-	16B12.5-S	16	12.5	-	M22	-	-	-
			ER32-	ER40-	17B13-S	17	13	-	-	M22	-	-
			ER32-	ER40-	18B14-S	18	14	-	M24	-	-	-
			ER32-	ER40-	19B15-S	19	15	-	-	M24	-	-
				ER40-	20B15-S	20	15	-	-	M27	-	-
				ER40-	20B16-S	20	16	-	M27、M30	-	-	M27
				ER40-	22B18-S	22	18	-	-	-	-	M30
				ER40-	22B19-S	22	19	-	-	M32、M33	-	-
				ER40-	22.4B18-S	22.4	18	-	M33	-	-	-
				ER40-	23B17-S	23	17	-	-	M30	-	-
				ER40-	25B19-S	25	19	-	-	M33	-	-

注：1. 安装丝锥时柄方必须伸入筒夹方槽内部。 2. 选型前需确认丝锥柄径与四方尺寸。

1. The handle of the tap must be inserted into the square slot.

2. Please confirm the diameter of the taper shank and the size of the square before choosing the type.

GC强力弹性直筒夹  
GC Straight Collet

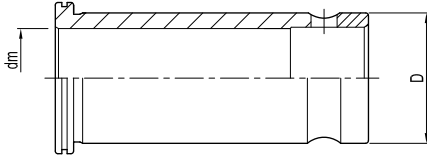

订货号 Ordering Code		尺寸 Dimension (mm)		特殊规格 (d)
		D	dm	
GC20-	6A-S	20	6	-
	8A-S	20	8	-
	10A-S	20	10	-
	12A-S	20	12	-
	16A-S	20	16	15
GC25	6A-S	25	6	-
	8A-S	25	8	-
	10A-S	25	10	-
	12A-S	25	12	-
	16A-S	25	16	-
	20A-S	25	20	-
GC32-	6A-S	32	6	-
	8A-S	32	8	-
	10A-S	32	10	-
	12A-S	32	12	-
	16A-S	32	16	15
	20A-S	32	20	19
	25A-S	32	25	24
GC42-	6A-S	42	6	-
	8A-S	42	8	-
	10A-S	42	10	-
	12A-S	42	12	-
	16A-S	42	16	15
	20A-S	42	20	19
	25A-S	42	25	24
	32A-S	42	32	31

OD型中心出水液压刀柄转换筒夹  
Hydraulic Collet - Internal Cooling

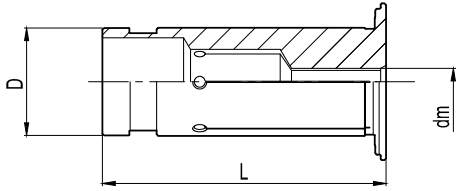

订货号 Ordering Code		尺寸 Dimension (mm)		
		dm	D	L
ODHC12-	3-S	3	12	45
	4-S	4	12	45
	5-S	5	12	45
	6-S	6	12	45
	8-S	8	12	45
ODHC20-	3-S	3	20	50.5
	4-S	4	20	50.5
	5-S	5	20	50.5
	6-S	6	20	50.5
	8-S	8	20	50.5
	10-S	10	20	50.5
	12-S	12	20	50.5
	14-S	14	20	50.5
ODHC32-	16-S	16	20	50.5
	6-S	6	32	60.5
	8-S	8	32	60.5
	10-S	10	32	60.5
	12-S	12	32	60.5
	14-S	14	32	60.5
	16-S	16	32	60.5
	18-S	18	32	60.5
20-S	20	32	60.5	
25-S	25	32	60.5	

SD高速刀柄专用螺帽  
Clamping Nuts For SD Collet Chuck

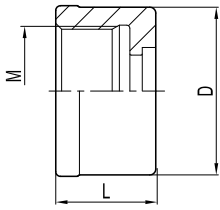

订货号 Ordering Code		尺寸 Dimension (mm)		
		D	L	M
SD	6-S	19.5	21	M15.5x1.0P
	10-S	27	24	M21.5x1.0P
	16-S	40	31	M32x1.5P
	20-S	48	33	M40x1.0P
	25-S	55	37	M45x1.5P

ER弹性筒夹刀柄螺帽  
Clamping Nut For ER Collet Chuck

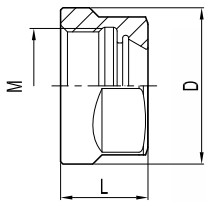

A

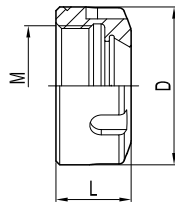

B

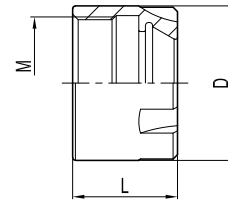

C



订货号 Ordering Code		图示 Figure	尺寸 Dimension (mm)		
			D	L	M
ER	16-A-S	A	28	17.5	M 22XP1.5
	20-A-S	A	34	19	M 25XP1.5
	25-UM/RD-S	B	42	20	M 32XP1.5
	32-UM/RD-S	B	50	22.5	M 40XP1.5
	40-UM/RD-S	B	63	25.5	M 50XP1.5
	11-M-S	C	16	12	M 13XP0.75
	16-M-S	C	23	18	M 19XP1.0
	20-M-S	C	28	19	M 24XP1.0
25-M-S	C	35	20	M 30XP1.0	

SD高速精密筒夹刀柄专用扳手  
Wrench For SD Tool Holder



订货号 Ordering Code		螺帽 Nuts	重量 Weight(kg)
TSD	6-S	SD6	0.30
	10-S	SD10	0.35
	16-S	SD16	0.40
	20-S	SD20	0.50
	25-S	SD25	0.55

ER弹性筒夹刀柄专用扳手  
Wrench For ER Tool Holder

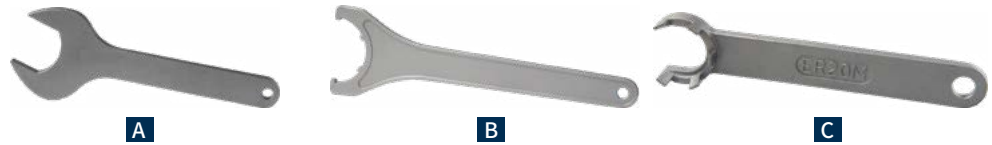

订货号 Ordering Code		图示 Figure	螺帽 Nuts	重量 Weight(kg)
TER	16-A-S	A	ER16-A	0.1
	20-A-S	A	ER20-A	0.1
	25UMKM/RD-S	B	ER25-UM/RD	0.2
	32UMKM/RD-S	B	ER32-UM/RD	0.2
	40UMKM/RD-S	B	ER40-UM/RD	0.3
	11-M-S	C	ER11-M	0.2
	16-M-S	C	ER16-M	0.2
	20-M-S	C	ER20-M	0.2
	25-M-S	C	ER25-M	0.2

GLC强力筒夹刀柄专用扳手  
Wrench For Tool Holder GLC



订货号 Ordering Code		适用刀柄 Tool holder (mm)	重量 Weight(kg)
TGLC	20-S	GLC20	0.1
	32-S	GLC32	0.1
	42-S	GLC42	0.2



L形扳手  
Allen Key

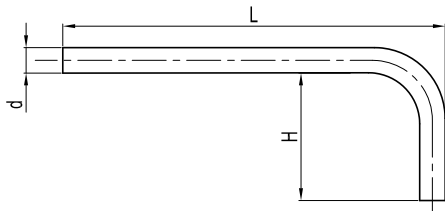

订货号 Ordering Code	尺寸 Dimension (mm)		
	d	L	h
TH03L-S	3	65	20
TH04L-S	4	70	25
TH05L-S	5	78	28
TH06L-S	6	85	32
TH08L-S	8	100	36
TH10L-S	10	105	40
TH12L-S	12	113	44
TH14L-S	14	118	48
TH17L-S	17	125	55

T形扳手  
Wrench - T

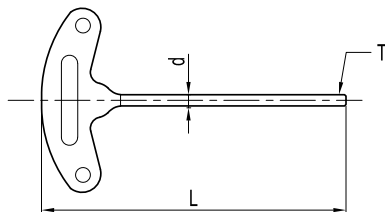

订货号 Ordering Code	尺寸 Dimension (mm)		
	d	L	h
TH03T-L-S	3	110	3
TH04T-L-S	4	120	4
TH05T-L-S	5	150	5
TH06T-L-S	6	170	6
TH08T-L-S	8	190	8

BT拉钉  
BT Pull Stud Without Hole

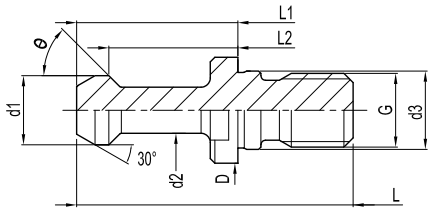

订货号 Ordering Code		尺寸 Dimension (mm)								重量 Weight(kg)	
		D	d1	d2	d3	L1	L2	L	θ		G
BT30-	45-S	16.5	11	7	12.5	23	18	43	45°	M12	0.03
	60-S	16.5	11	7	12.5	23	18	43	60°	M12	0.03
BT40-	45-S	23	15	10	17	35	28	60	45°	M16	0.07
	60-S	23	15	10	17	35	28	60	60°	M16	0.07
	90-S	23	15	10	17	35	28	60	90°	M16	0.07
BT50-	45-S	38	23	17	25	45	35	85	45°	M24	0.25
	60-S	38	23	17	25	45	35	85	60°	M24	0.25
	90-S	38	23	17	25	45	35	85	90°	M24	0.25

BT出水拉钉  
BT Pull Stud With Cooling Hole

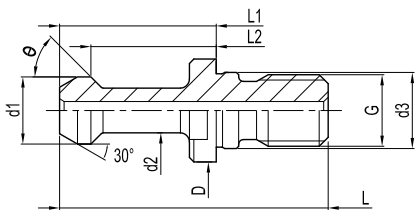

订货号 Ordering Code		出水孔径 Coolant dia.	尺寸 Dimension (mm)								重量 Weight(kg)	
			D	d1	d2	d3	L1	L2	L	θ		G
BT40-	45C-S	4	23	15	10	17	35	28	60	45°	M16	0.07
	60C-S	4	23	15	10	17	35	28	60	60°	M16	0.07
	90C-S	4	23	15	10	17	35	28	60	90°	M16	0.07
BT50-	45C-S	6	38	23	17	25	45	35	85	45°	M24	0.25
	60C-S	6	38	23	17	25	45	35	85	60°	M24	0.25
	90C-S	6	38	23	17	25	45	35	85	90°	M24	0.25

MAZAK拉钉  
MAZAK Pull Stud

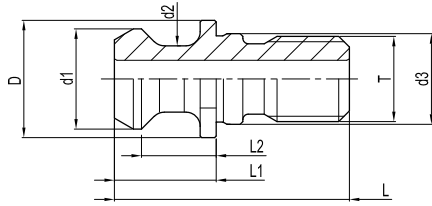

订货号 Ordering Code		尺寸 Dimension (mm)								重量 Weight(kg)
		D	d1	d2	d3	L	L1	L2	T	
MAZAK	40-S	22	18.8	12.45	17	44.1	19.1	14	M16	0.02
	50-S	37	28.96	20.83	25	65.2	25.2	25.55	M24	0.1

MTB拉紧拉钉  
MTB Tension Screw

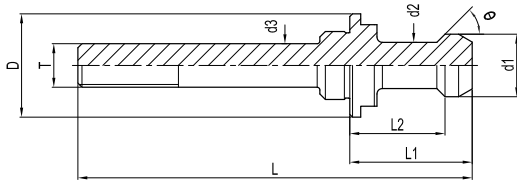

订货号 Ordering Code		尺寸 Dimension (mm)								重量 Weight(kg)	
		D	d1	d2	d3	L1	L2	L	$\theta$		T
BT40-	45-MT4-S	23	15	10	17	35	28	110	45°	M16	0.1
BT50-	45-MT5-S	38	23	17	25	45	35	165	45°	M20	0.65





D

附录

APPENDIX

## 热缩刀柄使用注意事项 Announcements

### 快速加热原理 / Heating

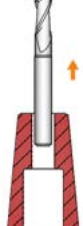
加热 Heating	置入刀具 Inserting	固定夹持 Cooling	取出 Removing
			
将刀具置加热器内加热， Place tool holder in heating	将刀具置入加热膨胀后的刀柄 Insert the cutter to the expanded holder	温度冷却收缩后的刀柄，可稳固 夹持刀具 Cool the holder and hold the cutter	刀柄在加热膨胀后，可轻易取出 刀具 Heat the holder and remove the cutter

### 使用工具/Tools

- 薄壁及孔径为 $\phi 8$ 以下规格的刀柄，仅适用于硬质合金刀具的装夹。  
The holder with thin-walled and hole diameter below 8mm is only suitable for the clamping of cemented carbide tools.
- 使用公差范围外的刀具是刀柄破损和发生滑落事故的原因。  
No shrink release is possible for any tool for high speed steel.
- 刀具柄部的细小铁屑等附着物会和阻碍夹持孔正常装夹，造成刀具无法拔出。  
A tools exceeding its tolerance can cause breakage or slippage.

### 拉钉 (BT) /Retention Knob(BT)

- 请利用出水拉钉，否则请将拉钉取下后再进行加热。  
Use a retention knob that has perforations, or remove the retention knob and heat it.
- 通常拉钉不排出空气就不能放入刀具。  
The typical retention knob has no vent to release air, preventing tools from being inserted

### 冷却液导管 (HSK) / Coolant Duct(HSK)

- 请带着冷却液导管加热时，会破坏导管的O型环。  
Heating the holder with coolant duct attached, the o-ring will be damaged.
- 加热时，请卸下冷却液导管。  
Remove the coolant duct before heating the holder.

### 水冷时的注意 Precautions For Water-Cooling

- 热装之后水冷，产生大量水蒸气，有烫伤的危险性。  
Water-cooling immediately after shrink fitting may result in burns due to the large quantity of steam generated.
- 请在热装装置冷却1分钟以上之后进行水冷。  
Be sure to set the shrink-fitting heater setting to cool and cool the holder for at least one minute before water-cooling it.
- 请完全除去水分。残留水分后，生锈会引起刀柄破损。  
Moisture left on the holder may lead to rust formation and damage to the holder, so be sure to completely remove all moisture.

HSK柄尺寸图  
HSK Tool Holder Ordering Code - DIN69893

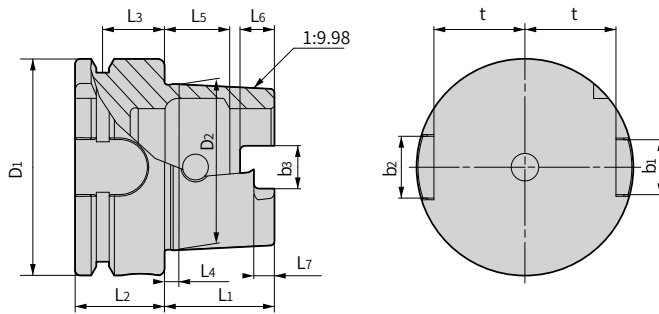

订货号 Ordering Code	尺寸 Dimension												
	D1	D2	L1	L2	L3	L4	L5	L6	L7	b1	b2	b3	t
HSK40A	40	30.007	20	20	16	4	11.42	6	3.5	11	9	8.05	17
HSK50A	50	38.009	25	26	18	5	14.13	7.5	4.5	14	12	10.54	21
HSK63A	63	48.01	32	26	18	6.3	18.13	10	6	18	16	12.5	26.5
HSK100A	100	75.013	50	29	20	10	28.56	15	10	22	20	20	44

BT柄尺寸图  
BT Tool Holder Ordering Code - MAS403BT

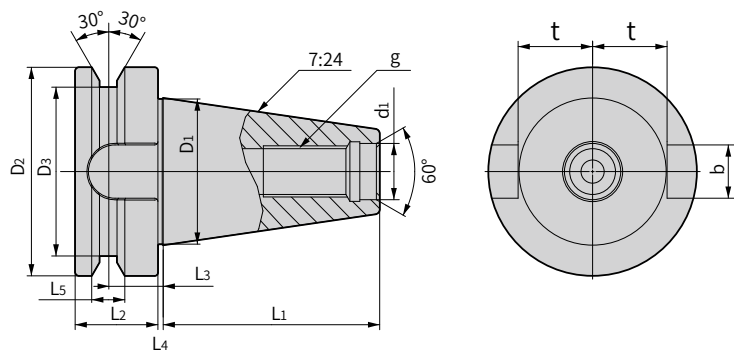

订货号 Ordering Code	尺寸 Dimension											
	D1	d1	L1	D2	D3	L2	L3	L4	L5	b	t	g
BT30	31.75	12.5	48.4	46	38	20	13.6	2	8	16.1	16.3	M12
BT40	44.45	17	65.4	63	53	25	16.6	2	10	16.1	22.6	M16
BT50	69.85	25	101.8	100	85	35	23.2	3	15	25.7	35.4	M24









---

+ 华东大区

上海市青浦区华强街路三友星墅 203 弄272号 302 室  
联系电话: +86-0592-3706375

+ 华南大区

广东省东莞市长安镇德政中路信义怡翠豪园9栋1单元902  
联系电话: +86-0592-7310125

+ 西部大区

四川省成都市龙泉驿区成都航空职业技术学院  
联系电话: +86-0592-7301561

+ 华北大区

天津市河东区海河东路与八经路交口以东八经路81号 中海钻  
石湾信和苑 11号楼1门4204室  
联系电话: +86-0592-7301126

+ 华中大区

武汉经济技术开发区28R地块金色港湾4期26栋2号  
联系电话: +86-0592-7310203

+ 东北大区

辽宁省沈阳市铁西区建设东路158号华润铁西中心写字楼2109  
联系电话: +86-0529-7306375

---

## 厦门金鹭特种合金有限公司

地址: 中国厦门市湖里区兴隆路69号  
工厂地址: 中国厦门同安工业集中区集成路1601-1629号  
电话: +86-592-7107392  
传真: +86-592-7107322  
邮编: 361006  
电邮: gesac@cxtc.com

[www.gesac.com.cn](http://www.gesac.com.cn)



GE202303I

---