

# 通用机械行业加工解决方案

Manufacturing Solutions for General Mechanical Industry



+ 华东大区  
Eastern China Region

上海市青浦区华强街路三友星墅 203 弄272号 302 室  
Add: Room 302, No. 272, Lane 203, Sanyou Xingshu  
Huaqiang Street Road, Qingpu District, Shanghai  
Tel: +86-0592-3706375

+ 华南大区  
Southern China Region

广东省东莞市长安镇德政中路信义怡翠豪园9栋1单元902  
Add: 902, Unit 1, Building 9, Xinyi Yicui Haoyuan  
Dezheng Middle Road, Chang'an Town  
Dongguan City, Guangdong Province  
Tel: +86-0592-7310125

+ 西部大区  
West Region

四川省成都市龙泉驿区成都航空职业技术学院  
Add: Chengdu Aviation Vocational Technology College  
Longquanyi District, Chengdu City, Sichuan Province  
Tel: +86-0592-7301561

+ 华北大区  
Northern China Region

天津市河东区海河东路与八经路交口以东八经路81号  
中海钻石湾信和苑 11号楼11门4204室  
Add: Room 4204, Gate 1, Building 11, xinheyuan, Diamond Bay  
Hedong District, Tianjin, China  
Tel: +86-0529-7306375

+ 东北大区  
Northeast Region

辽宁省沈阳市铁西区建设东路158号华润铁西中心写字楼2109  
Add: No.2109(china Resources Tiexi Center)No.158 Jianshe East Road  
Tiexi District Shenyang City Liaoning Province  
Tel: +86-0592-7301126

+ 华中大区  
Central China Region

武汉经济技术开发区28R地块金色港湾4期26栋2号  
Add: No. 2, Building 26, Golden Harbor Phase 4, Block 28R  
Wuhan Economic and Technological Development Zone  
Tel: +86-0592-7310203

厦门金鹭特种合金有限公司  
XIAMEN GOLDEN EGRET SPECIAL ALLOY CO.,LTD.

地址: 中国厦门市湖里区兴隆路69号  
Add: No.69 Xinglong Road Huli District Xiamen CHINA  
工厂地址: 中国厦门同安工业集中区集成路1601-1629号  
Factory Add: No.1601-1629 Jicheng Road Industrial  
Concentration Area Tongan Xiamen CHINA  
Tel: +86-592-7107392 Fax: +86-592-7107322  
PC: 361006 Email: gesac@cxtc.com

www.gesac.com.cn

400-998-6858



GE202303e



厦门金鹭特种合金有限公司, 成立于 1989 年, 是一家中外合资的国家高新技术企业, 隶属于中国六大稀土集团之一的厦门钨业股份有限公司。公司致力于高品质钨粉末材料、硬质合金、精密切削工具等钨系列产品的研发、生产, 以及行业专业解决方案的提供, 是世界知名的钨粉末、硬质合金及切削工具供应商。

凭借完整钨产业链的产品集成技术研发, 以及务实、创新的管理理念, 厦门金鹭始终保持着强劲的发展势头, 为全球用户提供最高性价比的产品和服务, 为现代工业领域解决高硬度、耐高温、耐磨损问题, 提供了优良的产品和完善的解决方案, 客户遍布全球四十多个工业发达国家和地区, 享誉海内外。

公司拥有国内 4 个生产基地和 1 个国家级企业研发中心, 海外 3 个销售公司和 1 个海外生产基地, 独立承担并完成多项“国家科技支撑计划项目”, “国家科技重大专项”, “国家火炬计划项目”, “国家重点新产品”开发项目及省市重点研究课题, 被评为“战略性新兴产业骨干企业”、“创新型企业”、“先进科技企业”。

Xiamen Golden Egret Special Alloy Co., Ltd. (GESAC), founded in 1989, is a Sino-foreign joint venture with national high-tech, affiliated with XTC, which is one of six major rare earth groups in China. GESAC is committed to research & development, production and professional solutions providing of high-quality tungsten powder materials, cemented carbide, precision cutting tools and other tungsten products. Up to now, GESAC has become world-famous manufacturer and supplier of tungsten powder, cemented carbide and precision cutting tools products.

With the Integrated Product Development of complete tungsten industry chain, as well as a pragmatic and innovative management concept, GESAC has always maintained a strong momentum of development, providing the cost effective tungsten powder products and services for global users, offering the excellent products and perfect solutions for solving high hardness, high temperature resistance and wear resistance topics. Our brand "Golden Egret" has become one of the leading brand in the market, enjoying famous reputation in more than 40 countries and regions.

GESAC owns four production headquarters and one national level research center domestically, and three sales branches and one production base overseas. We undertook and completed several development programs independently, including the “National Science and Technology Support Programs”, the “National Torch Program Projects”, and the “National Key Projects” and so on. GESAC was awarded as “Key Enterprise for Strategic Emerging Industry”, “Innovative Enterprise” and “Enterprise with Advanced Technology”.

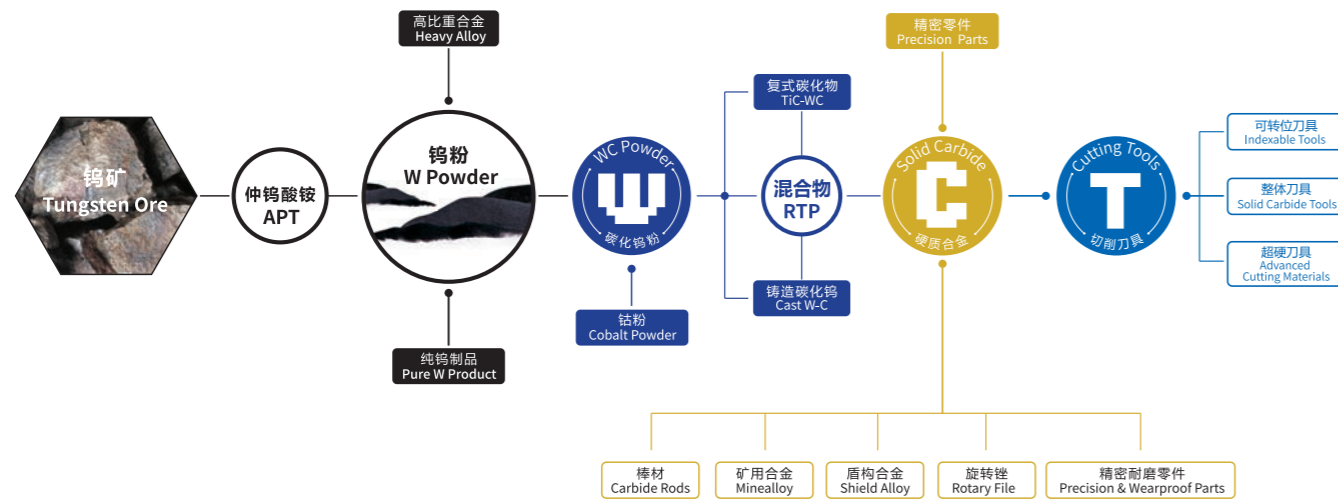

## 行星减速机加工解决方案 Manufacturing Solutions of Planetary Reducer

常规型-箱体 Conventional - Body	04
常规型-机盖 Conventional - Cover	06
常规型-行星架 Conventional - Planetary Shaft	08
常规型-输出轴 Conventional - Main Shaft	10
常规型-内齿圈 Conventional - Internal Gear	12
常规型-行星轮 Conventional - Planetary Wheel	14
常规型-太阳轮 Conventional - Sun Wheel	16
精密型-箱体 Precision - Body	18
精密型-行星架 Precision - Planetary Shaft	20

## 中型轴承加工解决方案 Processing Solutions for Medium-sized Bearings

内外圈、滚子 Inner And Outer Rings、Rollers	24
轴承行业刀具 Special Tools Of Bearings	26

# 行星减速机加工解决方案

Manufacturing Solutions of Planetary Reducer

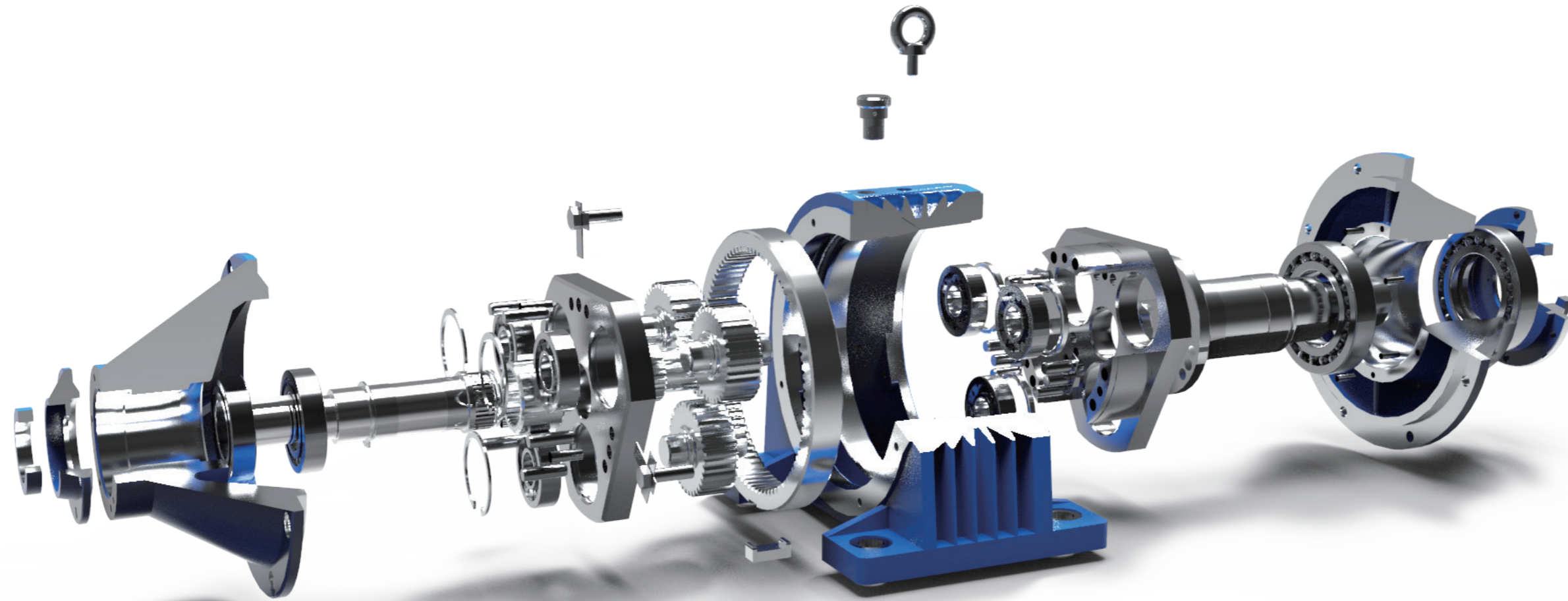

**螺纹孔加工  
Thread Hole Making**

• **D918S**

高性能硬质合金麻花钻  
High Performance Solid Carbide Twist Drill

适用于钢、铸铁加工，重点解决断续切削和冷却条件差等恶劣工况。

Suitable for processing steel, cast iron; aiming at solving processing problems in rough cutting conditions such as interrupted cutting or bad coolant condition.

• **T100系列丝锥**

T100 Tipper

螺旋槽高性能丝锥

High Performance Twist Tipper

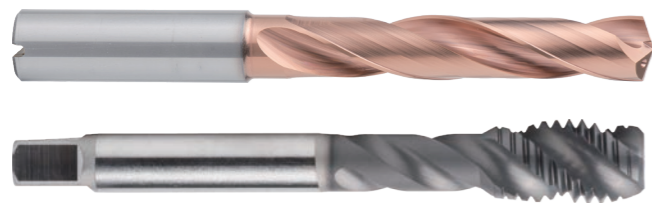

**底座安装孔加工  
Base Mounting Hole Making**

• **QPMG+GHD-S**

高效双螺旋内冷浅孔钻

High Performance Double Helix Internal Coolant Twist Drill

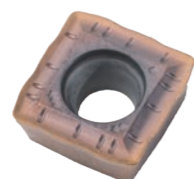

**安装面铣削  
Install Face Milling**

• **WNGU+MEE190**

双面曲线刃通用方肩铣削  
Universal Shoulder Milling With Double Face Curvilinear Cutting Edge



**镗孔  
Boring**

• **LRB系列**

LRB Series

大径粗镗刀

Large Diameter Rough Boring Cutter

• **LFB系列**

LFB Series

大径精镗刀

Large Diameter Fine Boring Cutter



**底部大平面铣削  
Bottom Large Surface Milling**

• **HNGU刀片+MFC160刀体**

多功能经济型双面12刃铣刀

Multifunctional 12 Edges Double Faces Surface Milling for Cast Iron

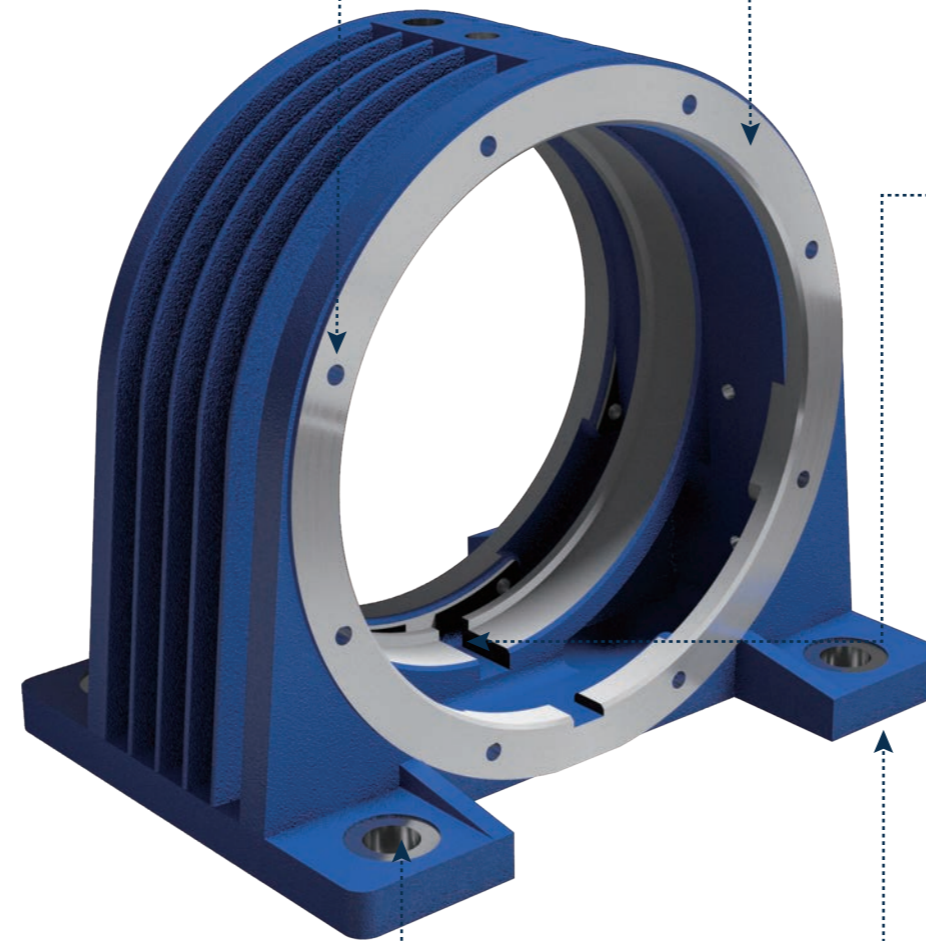

**孔加工  
Hole Making**

- **D918S**  
高性能硬质合金麻花钻  
High Performance Solid Carbide Twist Drill

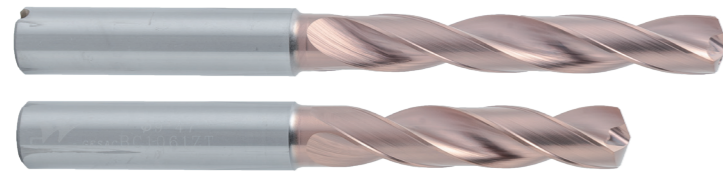

**内孔车削  
Internal Turning**

- **正型KM槽型+GK1100系列**  
Positive KM +GK1100 Grade Series  
铸铁加工专用车削刀具  
Turning Tool for Cast Iron

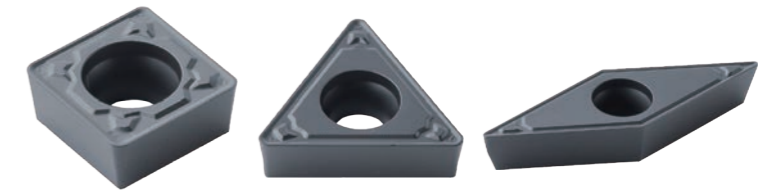

**外圆端面车削  
External Surface**

- **负型HK槽型+GK1200系列**  
Negative HK Geometry+ GK1200 Grade Series  
铸铁加工专用车削刀具  
Turning Tool for Cast Iron
- **修光刀WMV槽型+GK1120牌号**  
Wiper Edge WMV+GK1120 Grade  
铸铁加工专用车削刀具  
Turning Tool for Cast Iron

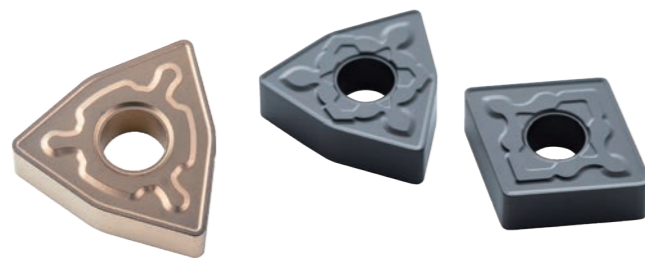

**螺纹孔加工  
Thread Hole Making**

- **T100系列丝锥**  
T100 Tipper  
螺旋槽高性能丝锥  
High Performance Twist Tipper

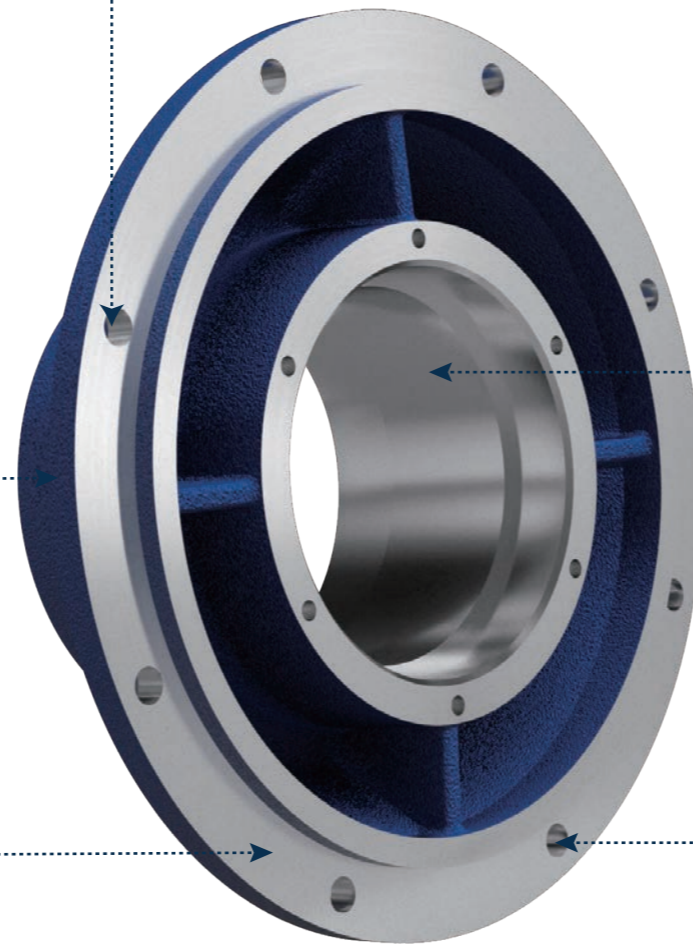

**孔加工  
Hole Making**

- D938  
普通钢加工硬质合金麻花钻  
Solid Carbide Twist Drill for Steel

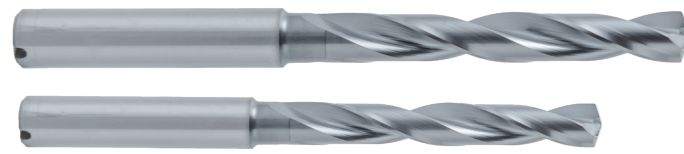

**镗孔  
Boring**

- RB系列  
RB Series  
粗镗刀  
Rough Boring Cutter
- FB系列  
FB Series  
精镗刀  
Fine Boring Cutter

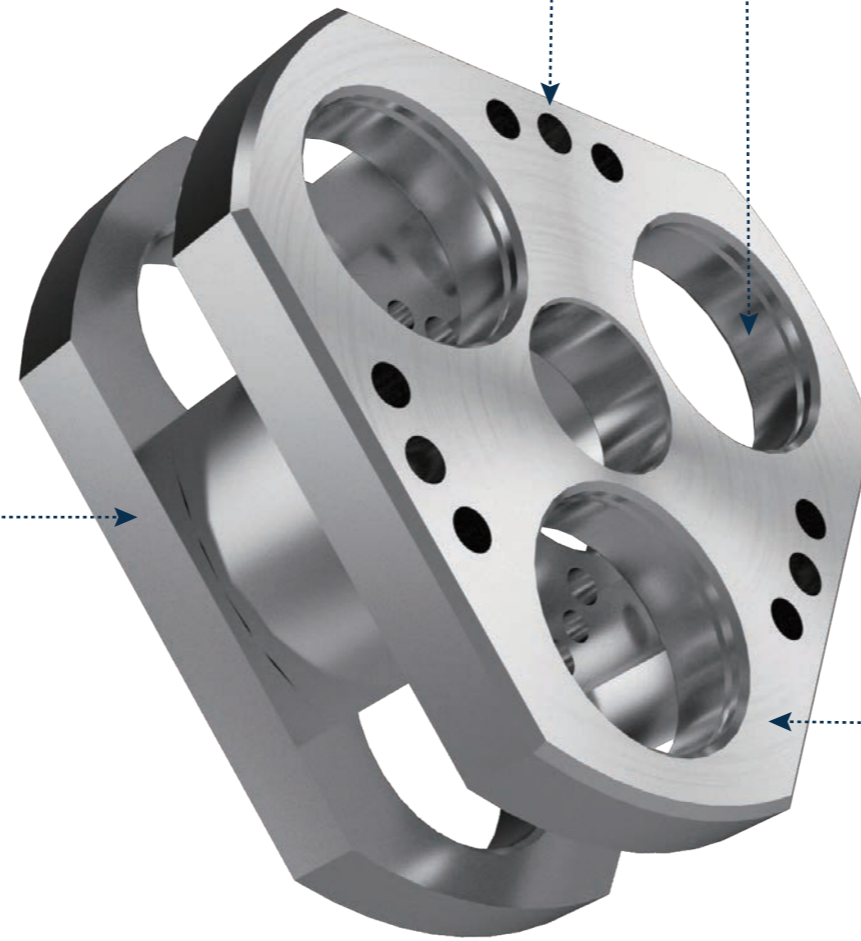

**方肩铣削  
Shoulder Milling**

- APKT+MEB190  
单面曲线刃方肩铣  
Single Face Curve Shoulder Milling



**平面铣削  
Face Milling**

- SNEU+MFB145/245  
高强度通用铣削  
Heavy Duty Universal Milling



### 孔加工 Hole Making

- D938  
普通钢加工硬质合金麻花钻  
Solid Carbide Twist Drill for Steel
- QPMG+GHD-S  
高效双螺旋内冷浅孔钻  
High Efficiency Double Helix Internal  
Coolant Shallow Hole Drill

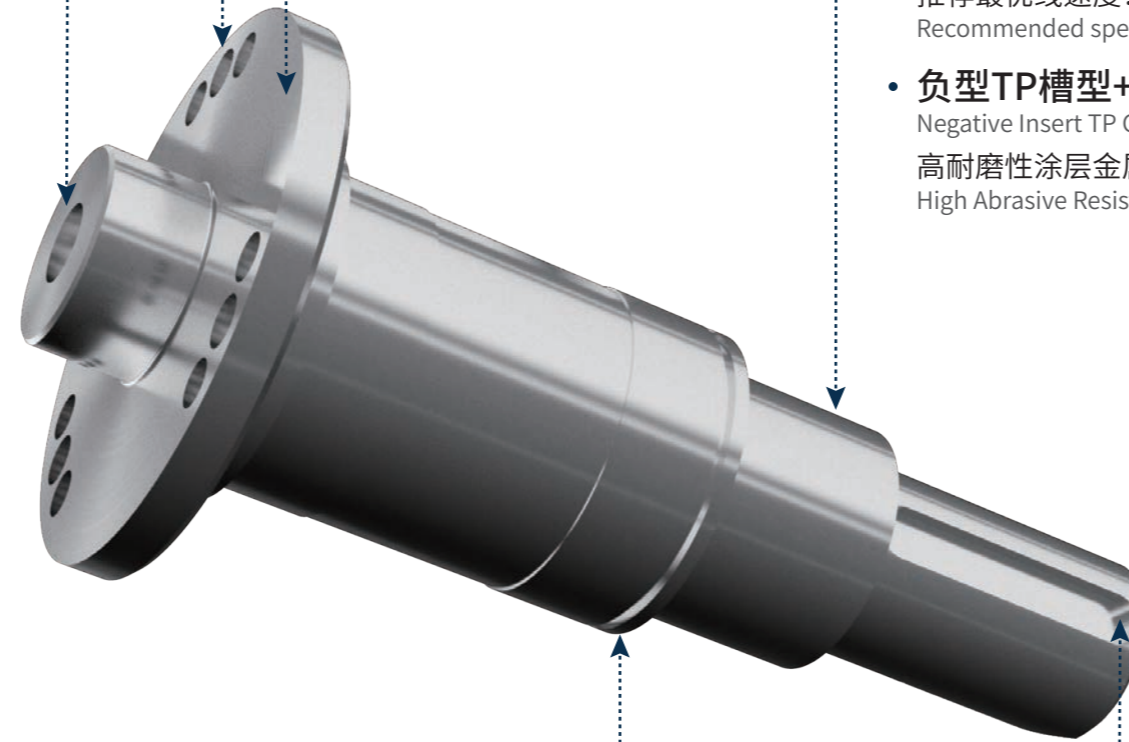

### 外圆及端面车削 External Surface Turning

- 负型Q系列+GPT6100系列  
Negative Insert Q Series+GPT6100 Grade Series  
GE.FORCE全新钢材高效车削刀具  
Newly Developed GE.FORCE High Efficiency Turning Tools for Steel  
推荐最优线速度:大于300m/min  
Recommended speed: >300m/min
- 负型TP槽型+GP31TM系列  
Negative Insert TP Geometry +GP31TM Grade Series  
高耐磨性涂层金属陶瓷车削刀具  
High Abrasive Resistance Coated Metallic Ceramic Turning Tool



### 油槽加工 Grooving

- MT/FG/GB系列  
MT/FG/GB Series  
高精确切槽切断系列刀具  
High Accuracy Grooving and Parting Inserts



### 键槽加工 Keyway Milling

- PP300  
普通钢高效加工立铣刀  
High Efficiency Endmill for Steel  
(D10铣刀加工碳钢, 最大金属去除率可达93.1cm<sup>3</sup>/min)  
(Maximum metal removal rate can reach 93.1cm<sup>3</sup>/min for D10 endmill when processing carbon steel)





**外圆端面车削  
External Surface**

- **负型Q系列+GPT6100系列**  
Negative Q Insert Series+GPT6100 Grade Series  
GE.FORCE全新钢材高效车削刀具  
Newly Developed GE.FORCE High Efficiency Turning Tool for Steel

**内孔车削  
Internal Turning**

- **正型MM系列+GPT6100系列**  
Positive MM Type Insert+GPT6100 Grade Series  
GE.FORCE全新钢材高效车削刀具  
Newly Developed GE.FORCE High Efficiency Steel Turning Tool

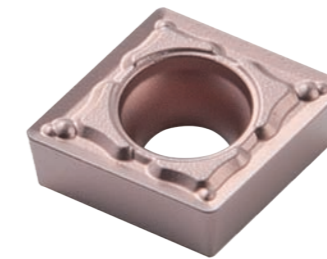

**键槽加工  
Keyway Milling**

- **SP210/PP300**  
普通钢高效加工立铣刀  
High Efficiency Endmill for Steel



**外圆端面车削(热处理后)  
External Surface Turning  
(After Annealing)**

- **PCBN-YP系列**  
PCBN-YP Series  
超硬车削刀具  
Hardened Turning Tools

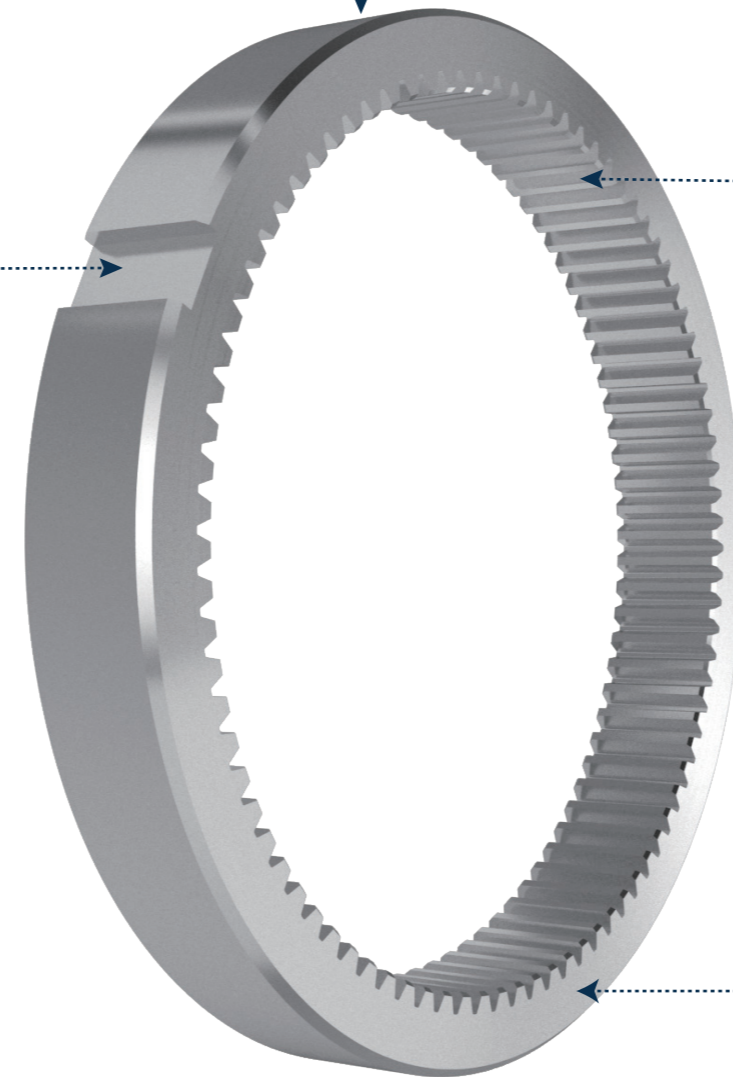
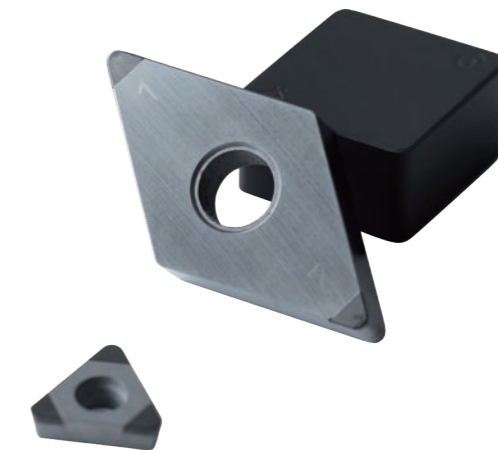



**外圆及端面车削**  
**External Surface Turning**

- **负型Q系列+GPT6100系列**  
Negative Q Insert Series+GPT6100 Grade Series  
GE.FORCE全新钢材高效车削刀具  
Newly Developed GE.FORCE High Efficiency  
Turning Tool for Steel



**倒角铣削**  
**Chamfer Milling**

- **SPMT+MCA130/145/160**  
倒角铣系列刀具  
Chamfer Milling Tools Series

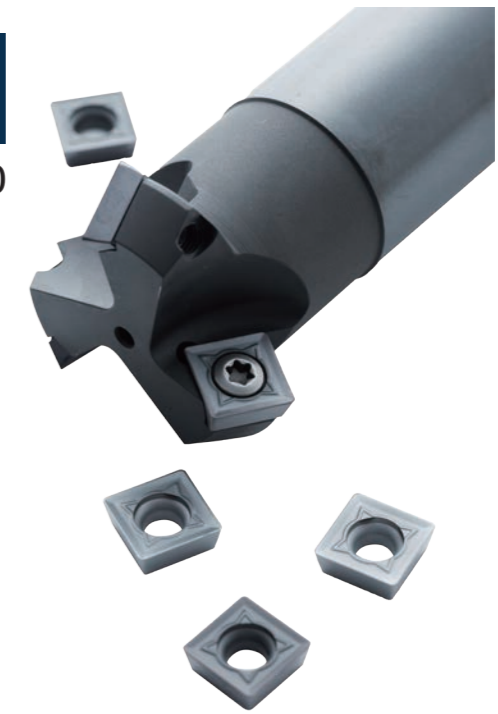

**外圆端面车削(热处理后)**  
**External Surface Turning (After Annealing)**

- **PCBN-YP系列**  
PCBN-YP Series  
超硬车削刀具  
Hardened Turning Tools

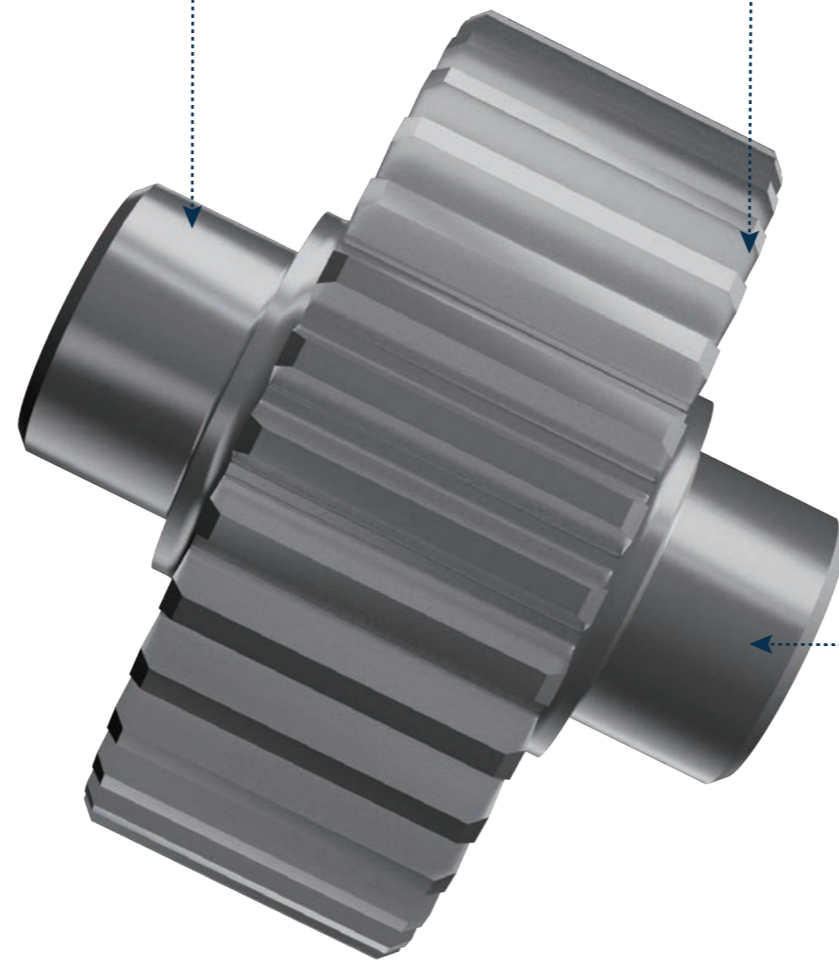

**外圆及端面车削**  
External Surface Turning

- **负型Q系列+GPT6100系列**  
Negative Q Insert Series+GPT6100 Grade Series  
GE.FORCE全新钢材高效车削刀具  
Newly Developed GE.FORCE High Efficiency Turning Tool for Steel



**外圆端面车削 (热处理后)**  
External Surface Turning (After Annealing)

- **PCBN-YP系列**  
PCBN-YP Series  
超硬车削刀具  
Hardened Turning Tools



**倒角铣削**  
Chamfer Milling

- **SPMT+MCA130/145/160**  
可转位倒角铣系列刀具  
Chamfer Milling Tools Series

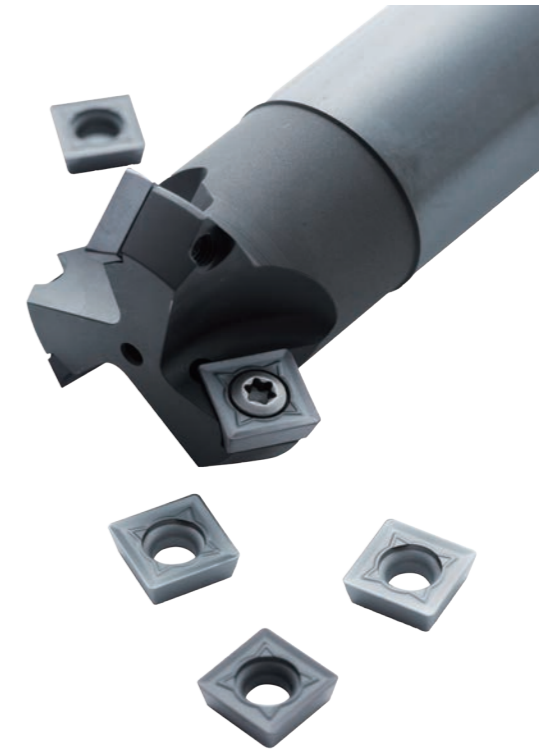

**孔加工**  
Hole Making

- **D938**  
普通钢加工硬质合金麻花钻  
Solid Carbide Twist Drill for Steel
- **QPMG+GHD-S**  
高效可转位钻头  
High Efficiency Indexable Drill

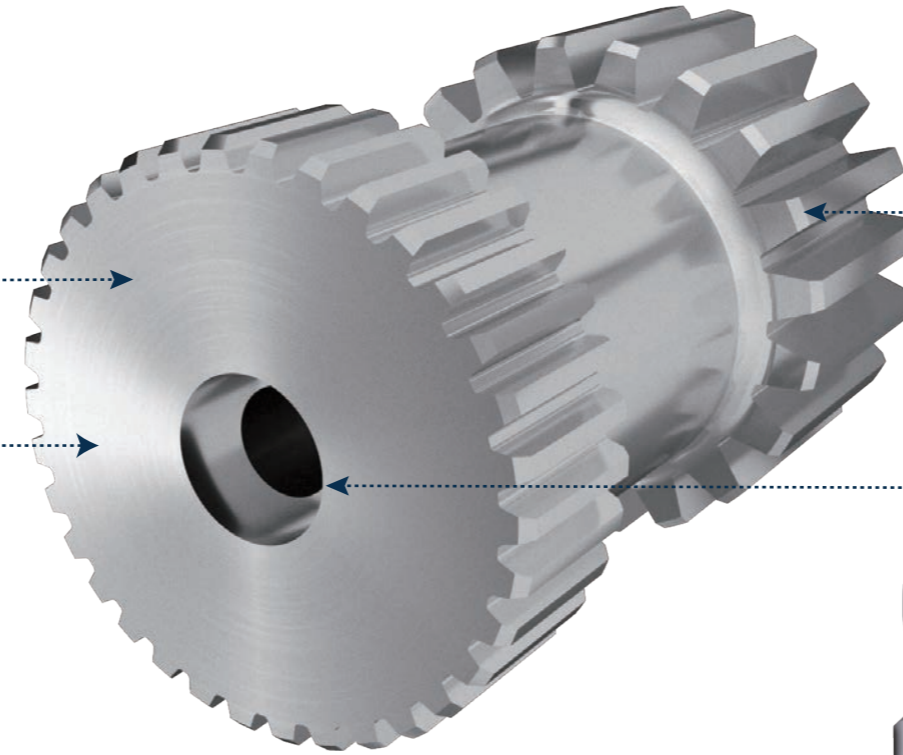



### 孔加工 Hole Making

- D938  
普通钢加工硬质合金麻花钻  
Solid carbide twist drill for steel.

### 内孔车削 Inner Hole Turning

- 正型MM系列+GPT6100系列  
Positive MM type insert+GPT6100 grade  
GE.FORCE全新钢材高效车削刀具  
Newly developed GE.FORCE high efficiency steel turning tool.

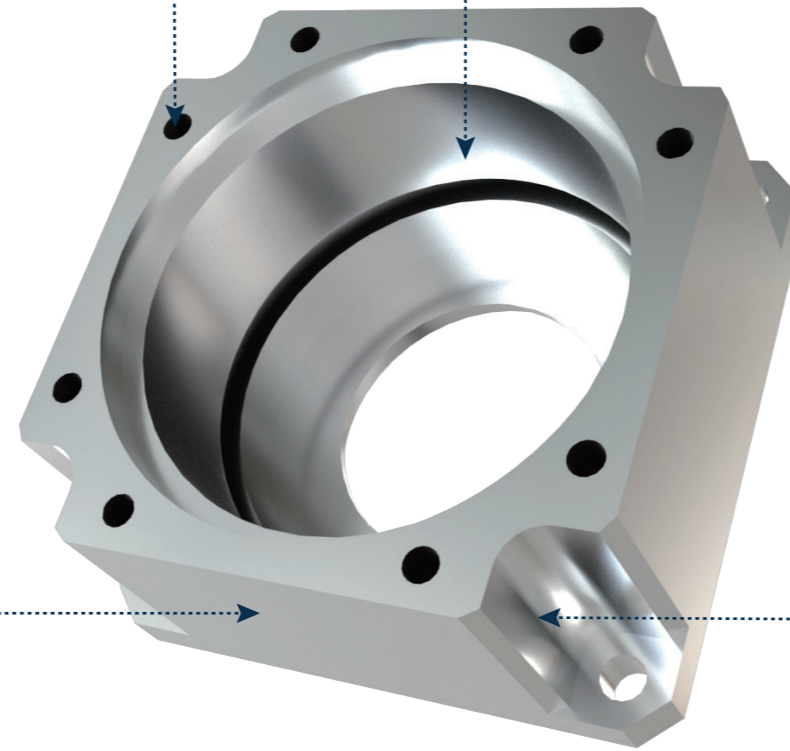
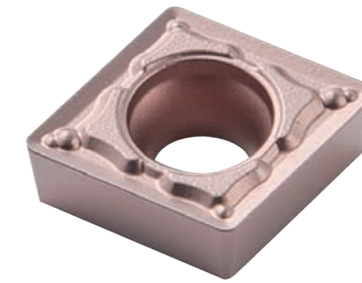

### 平面铣削 Face Milling

- SNEU+MFB145/245  
高强度通用铣削  
Heavy duty universal milling

### 外轮廓加工 Outer contour Mak

- 减速机高效加工刀具  
Efficient Machining Tool Of Reducer



### 外圆及端面车削 External Surface Turning

- 负型Q系列+GPT6100系列  
GE.FORCE全新钢材高效车削刀具  
Newly developed GE.FORCE high efficiency steel turning tool

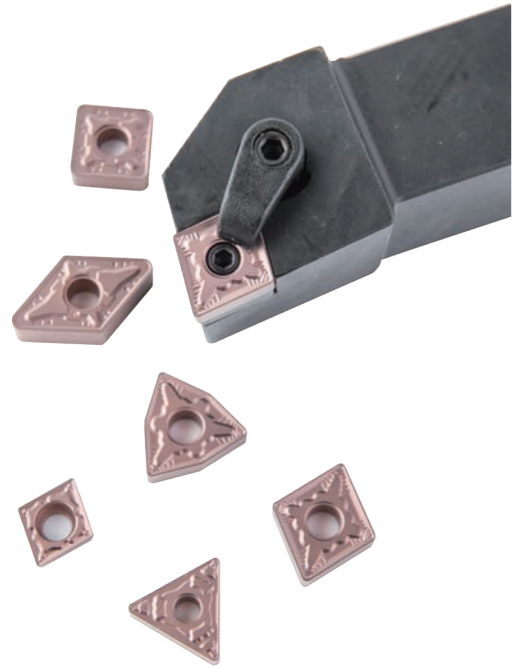

### 键槽加工 Key Slot Milling

- SP210/PP300  
普通钢高效加工立铣刀  
High efficiency endmill for steel



### 定位孔加工 Positioning hole processing

- D938  
普通钢加工硬质合金麻花钻  
Solid carbide twist drill for steel.
- 扩孔专用刀具  
减速机扩孔专用刀具  
Reducer reaming tool
- 高精度铰刀  
减速机高精度铰刀  
High precision reamer for reducer



### 窗口加工 Windows Milling

- QPMG+GHD-S  
高效可转位钻头  
High efficiency indexable drill
- 减速机高效加工刀具  
Efficient Machining Tool Of Reducer

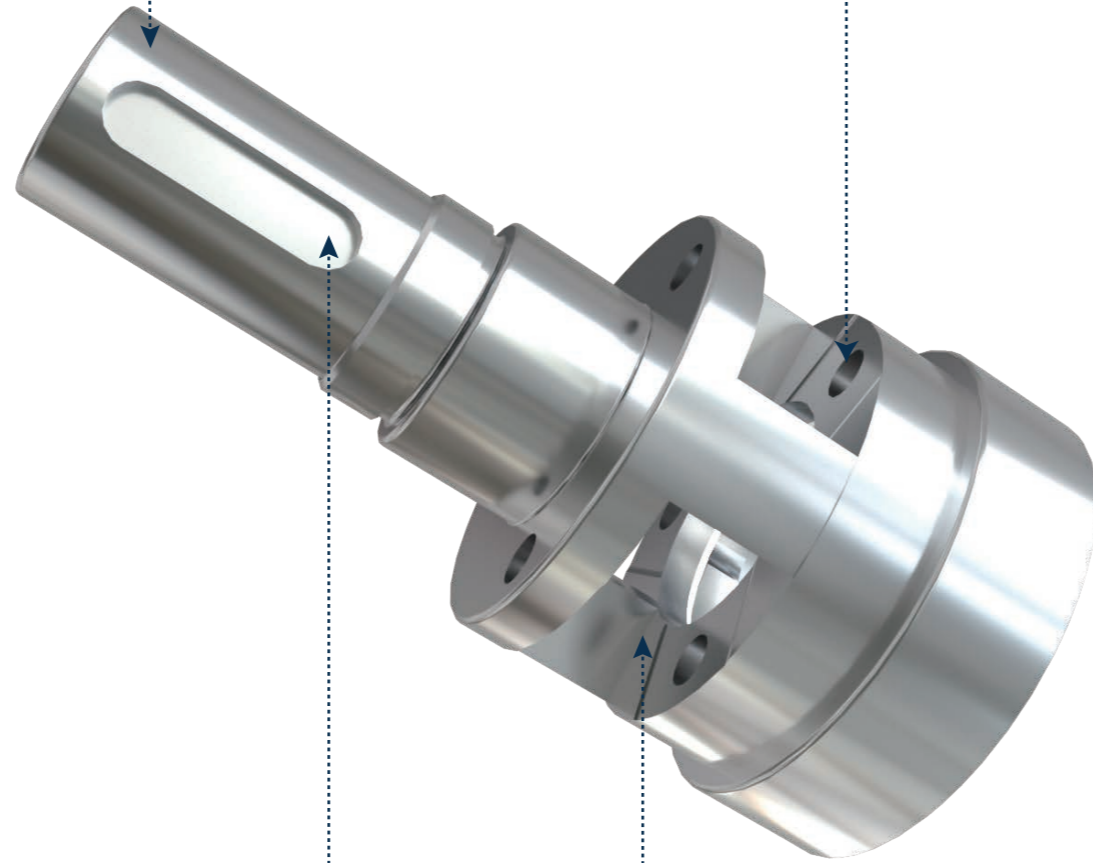

# 中型轴承加工解决方案

Processing solutions for medium-sized bearings

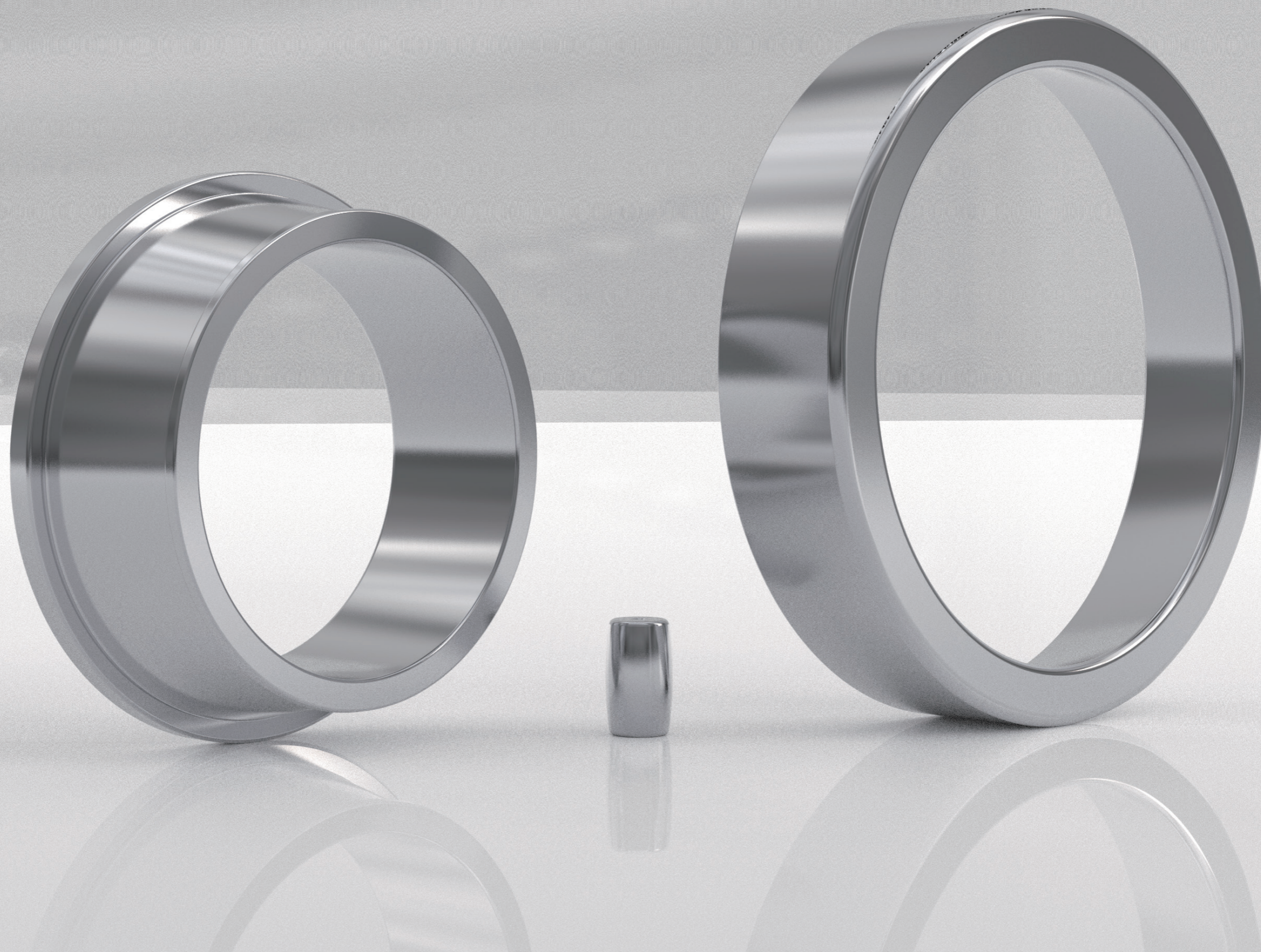

**切断加工  
Parting**

- **GTD-MC系列**  
GTD-MC Series  
高精度双头切断刀具  
High accuracy parting inserts



**端面及凹槽加工  
face machining**

- **正型MM系列+GPT6100系列**  
Positive Insert MM+GPT6100 grade  
钢材高效车削刀具  
High efficiency turning tools.  
D型刀片  
D-shaped inserts

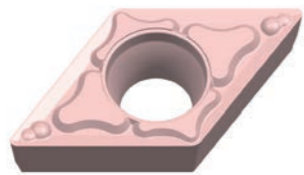

**滚道仿形加工  
Raceway profiling machining**

- **负型QM-GPT6100系列**  
Negative Insert Q Series+GPT6100 Grades  
钢材高效车削刀具  
High efficiency turning tools.  
V/D型刀片  
V/D-shaped inserts
- **T35型-QM系列**  
T35 shaped -QM Series  
3角V型刀片  
V-shaped inserts with three nose

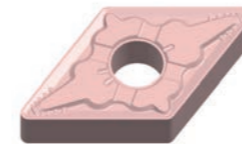
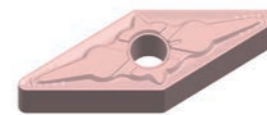

**外圆、倒角、端面加工  
Excircle, chamfer and end face machining**

- **负型QM-GPT6100系列**  
Negative Insert Q Series+GPT6100 Grades  
钢材高效车削刀具  
High efficiency turning tools.  
W/T型刀片  
W/T-shaped inserts

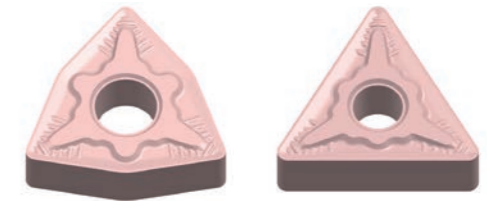

**内孔加工  
Inner hole machining**

- **负型QM-GPT6100系列**  
Negative Insert Q Series+GPT6100 Grades  
钢材高效车削刀具  
High efficiency turning tools.  
W型刀片  
W-shaped inserts





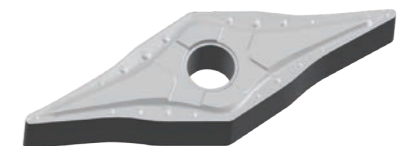
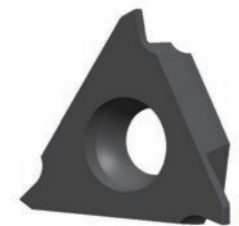

**防尘槽加工  
Dustproof groove machining**

- **GB系列**  
GB Series  
立装浅槽刀片  
Precision Grooving Inserts
- **Y型-TP系列**  
Y shaped -TP Series  
25°刀尖角刀片  
25° angle inserts

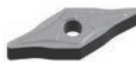
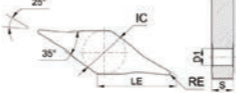

刀片 Inserts

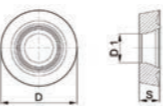
订货号 Ordering Code	尺寸 Dimension (mm)				涂层硬质合金 Coated Carbide			金属陶瓷 Cermet		形状 Shape
	IC	S	D1	RE	GP1105	GP1115	GP1225	GP31TM	GP91TM	
 YNGM160404-TP	9.525	4.76	3.81	0.4		○		●	○	
YNGM160408-TP	9.525	4.76	3.81	0.8		○		●	○	
 T35NMG070408-QM	12.7	4.76	5.16	0.8	○	●	○			
 RPMT1203M0	12	3.18	4.4	-		○			●	
RPMT1604M0	16	4.76	5.5	-		○			●	

T35NMG 外圆车刀杆  
External Turning Tool-holder of T35NMG

MTQNR/L

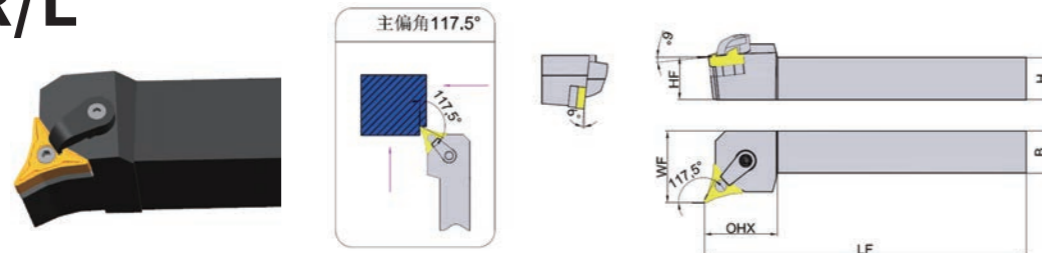

订货号 Ordering Code	尺寸 Dimension (mm)						匹配刀片 Insert	刀垫 Shim	销钉 Pin	压板 Clamp	双头螺丝 Screw	扳手 Wrench	重量 Weigh (KG)	库存 Stock	
	H	B	LF	OHX	HF	WF								R	L
MTQNR/L2525M07T35	25	25	150	32	25	32	T35NMG070408-QM	DT35N0704M	MLP46	MC620	MS625	S2.5/S3	0.79	●	○

●标准库存 ○需预定

TMTJNR/L

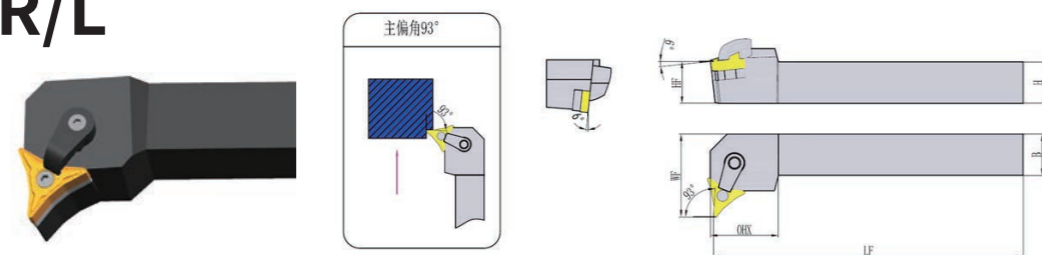

订货号 Ordering Code	尺寸 Dimension (mm)						匹配刀片 Insert	刀垫 Shim	销钉 Pin	压板 Clamp	双头螺丝 Screw	扳手 Wrench	重量 Weigh (KG)	库存 Stock	
	H	B	LF	OHX	HF	WF								R	L
TMTJNR/L2020K07T35	20	20	150	33	20	40	T35NMG070408-QM	DT35N0704M	MLP46	MC620	MS625	S2.5/S3	0.45	●	○

●标准库存 ○需预定

T35NMG 外圆车刀杆  
External Turning Tool-holder of T35NMG

TMTQNR/L

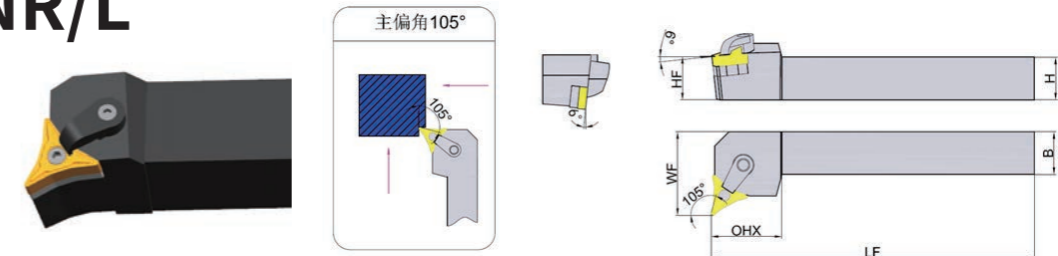

订货号 Ordering Code	尺寸 Dimension (mm)						匹配刀片 Insert	刀垫 Shim	销钉 Pin	压板 Clamp	双头螺丝 Screw	扳手 Wrench	重量 Weigh (KG)	库存 Stock	
	H	B	LF	OHX	HF	WF								R	L
TMTQNR/L2020K07T35	20	20	150	33	20	32	T35NMG070408-QM	DT35N0704M	MLP46	MC620	MS625	S2.5/S3	0.45	●	○

●标准库存 ○需预定

T35NMG内孔车刀杆  
Internal Turning Tool-holder of T35NMG

MTUNR/L

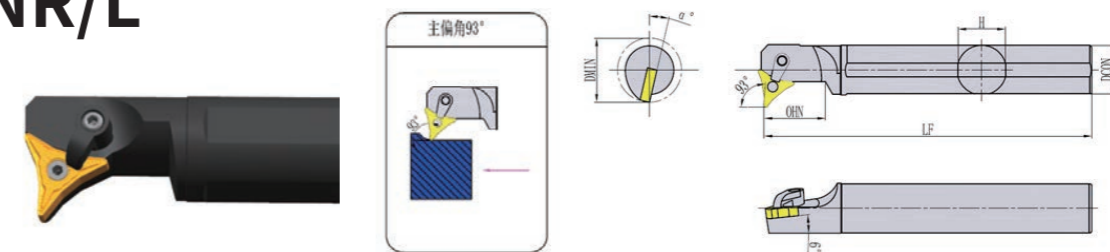

订货号 Ordering Code	尺寸 Dimension (mm)							匹配刀片 Insert	刀垫 Shim	销钉 Pin	压板 Clamp	双头螺丝 Screw	扳手 Wrench	重量 Weigh (KG)	库存 Stock	
	DMIN	DCON	WF	LF	OHN	H	α°								R	L
TS25SMTUNR/L07T35	33	25	18.5	250	31	23	6	T35NMG070408-QM	无	MLP44	MC515	MS520	S2.5	0.4	●	○

●标准库存 ○需预定

