



Magnetic welding aids



The Ace for Metal

assfalg

Assfalg GmbH

Buchstraße 149
73525 Schwäbisch Gmünd
Germany

Phone +49 (0) 71 71 92 505-0

Fax +49 (0) 71 71 92 505-50

info@assfalg-metal.com

www.assfalg-metal.com

Magnetic welding aids

03



MS | SW | MAV | PA
Magnet welding angles

02



MST
Magnet welding angles

07



Magsquare
Magnetic module

03



V-PAD | MAG-TAB
Magnetic welding aids

08



A 90 | Boomer
Magnet welding angles

04



Other products in the overview

09



HL 60-CE | HL 60-CE-L
Manual magnet transporter

05



Ground magnets
Magnetic ground clamps

06

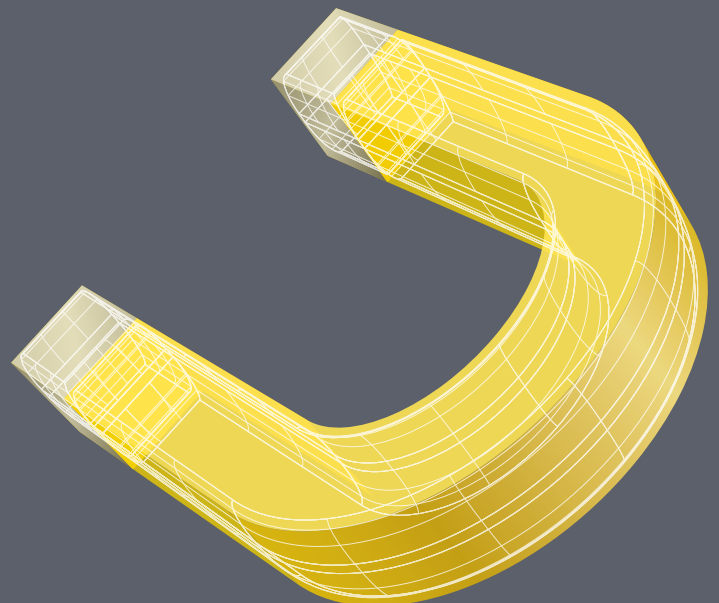

MS | SW | MAV | PA

Magnet welding angles

Your universal handyman for small welding and assembly works, for round and flat materials. All magnetic angles are switchable and suitable for flat and round material, except SW.

MAV 120 and PA 200 are stepless angle adjustable.



MS



SW



MAV 120



MSA



PA 200

Features

- Easy positioning, adjusting and fixing of workpieces
- No disruption of the arc when welding
- MS, MAV 120 and PA 200 each thigh is switchable
- MAV 120 and PA 200 have an easy and exactly angle adjustment by a quick release and scale



Technical data	Dimensions	Angle	Switchable	Use also for round material	Adhesive force	Weight	No.
	[L×W×H] [mm]						
MSA I	110 x 30 x 95	45°/90°	Yes	Yes	36	0,7	45338
MSA II	150 x 35 x 130	45°/90°	Yes	Yes	60	1,4	45339
MS 2-80	153 x 38 x 153	90°	Yes *	Yes	46	1,2	48192
MS 2-90	195 x 46 x 195	90°	Yes *	Yes	68	2,7	18736
MAV 120	197 x 50 x 197	25° - 275°	Yes *	Yes	41	2,4	162
PA 200	240 x 41 x 240	22° - 270°	Yes *	Yes	90	1,6	60343
SW 200	200 x 50 x 200	90°	No	No	40	2,5	46504
SW 300	300 x 50 x 300	90°	No	No	60	4,0	46503

* Every thigh is separately switchable

Magsquare

Magnetic module

Universal welding and mounting help. The magnetic force acts on 3 sides. It can also be used as an addition to magnetic angle A 90 and Boomer. Several threaded holes already exist as fastening options.



Features

- ✔ Magnets can be completely switched off by just turning the switch lever by 180°
- ✔ Usable for round and square workpieces
- ✔ Retention force acts on all sides
- ✔ Threaded holes on every side for individual take-up or mounting



Technical data

	Dimensions [LxWxH]	Adhesive force	Weight	No.
	[mm]	[kg]	[kg]	
MSQ 165	48 x 31 x 65	68	0,3	61939
MSQ 400	64 x 42 x 90	181	0,9	60971
MSQ 600	75 x 52 x 106	272	1,4	60972
MSQ 1000	72 x 108 x 147	454	3,4	60973

A 90 | Boomer

Magnet welding angles

Your compact helper for welding or assembly works, for round and flat materials at an angle of 90° (A 90), or at an angle of 0° - 360° (Boomer).



A 90



Boomer



Features

- ⌚ Magnets can be completely switched off by just turning the switch lever by 180°
- ⌚ Usable as inside and outside angle
- ⌚ Usable for round and square workpieces
- ⌚ Retention force acts on all sides
- ⌚ Even more magnetic force with optional extensible magnetic modules (A 90)
- ⌚ Sturdy steel construction of the angle (A 90)
- ⌚ Engraved scales for exact angle adjustment, 0 - 360° (Boomer)
- ⌚ Fast and easy angle adjustment by means of quick release (Boomer)

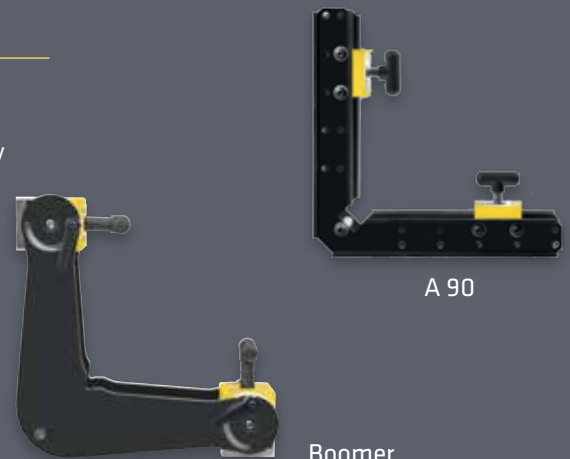

A 90

Boomer

Technical data

	Dimensions [L×W×H]	Adhesive force	Weight	No.
	[mm]	[kg]	[kg]	
A 165	205 x 205 x 47	68	0,8	61945
A 400	288 x 288 x 104	181	2,8	60340
A 600	288 x 288 x 134	272	3,7	60341
A 1000	287 x 474 x 145	454	4,6	60342
BA 150	196 x 196 x 80	68	1,3	60344
BA 400	257 x 257 x 109	181	3,0	60345
BA 600	257 x 257 x 169	272	4,4	60346

HL 60-CE | HL 60-CE-L

Permanent Magnet Handlifter

The permanent magnet handlifter HL 60-CE is especially designed for hot or sharp edged flamecut parts. It gets magnetized or demagnetized over push buttons on the handle. The HL 60-CE accu lasts for 1000 switching cycles before recharging. The charger and an exchange accu are included.

The **HL 60-CE-L** is with long handle.



HL 60-CE



HL 60-CE-L

Application

- ▶ Usable in mechanical engineering, tool manufacturing, plant engineering, steel construction, shipbuilding, steel mill, transport company or materials store
- ▶ For flat and round material
- ▶ Fast handling of sharp edged or hot metal parts

Features

- ⌚ Electric clamping and loosening at the push of a button
- ⌚ Max. operation temperature 80°C
- ⌚ Keeps being absolutely clean after switching-off - no dirt, no particles or chips are sticking!
- ⌚ Up to 1,000 switches are possible with only one battery charge

Options

- ⌚ Service and repair according to the safety rules

Delivery contents

- ⌚ HL 60-CE | HL 60-CE-L
- ⌚ Charger 230V with 2 x accu 12V

Technical data

	Hold surface	Lifting force	Sheet thickness	Weight	No.
	[mm]	[kg]	[mm]	[kg]	
HL 60-CE	56 x 42	30	> 5	1,1	60347
HL 60-CE-L	56 x 42	30	> 5	2,5	69924

Ground magnets

Magnetic ground clamps

Magnetic ground clamps are extremely useful tools to produce quickly and flexibly the grounding to the welding machine with a switch rotation, without searching suitable clamping locations for the welding clamp.



Features:

- ✔ Extremely fast connection of the welding ground
- ✔ Attachment to flat and rounded surfaces, like tubes
- ✔ Safe connection of the welding ground with one switch rotation
- ✔ Stay clean. Turn off ground clamp and wipe away debris
- ✔ Stable attachment of the welding ground
- ✔ No deformation of the surface



300 A - 800 A

Technical data	Dimensions [LxWxH] [mm]	Use also for round material	Adhesive force [kg]	Weight [kg]	No.
300 A	73 x 49 x 57	Yes	36	0,4	62088
600 A	69 x 100,8 x 66	Yes	60	0,8	61985
800 A	98,6 x 119,9 x 74	Yes	46	1,6	64698

MST

Corner magnetic welding angles

Easy magnetic angle for tack welding, especially for the inside.

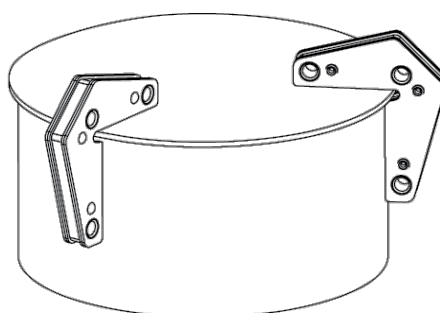
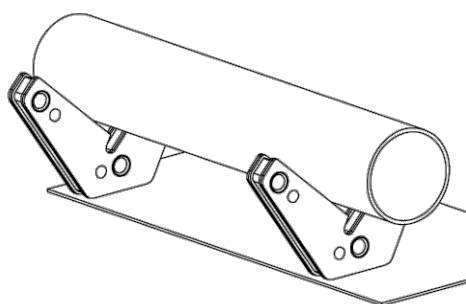

Features

- ☑ Inside and outside magnetic
- ☑ For welding angles from 60° - 90° - 120°

Delivery contents

- ☑ 1 x package: 2 corner magnetic angles

Technical data

Technical data	Dimensions	Lifting force	Weight	No.
	[mm]	[kg]	[kg]	
MST 327	95 x 83 x 16	14	0,4	30324

V-PAD | MAG-TAB

Magnetic welding aids

For holding and positioning lightweight, magnetic metal parts.



V-PAD



MAG-TAB

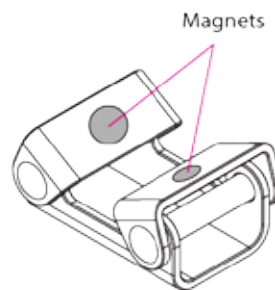
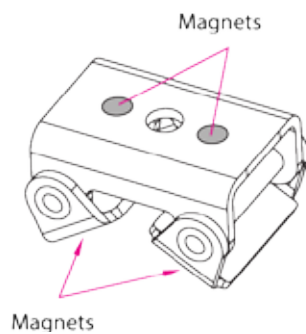

Features

- ✔ 4 magnets clamp safely the V-PAD on the workpiece and on the welding table
- ✔ For round and flat parts
- ✔ Aid for metal parts, parallel or vertical to the substructure

Delivery contents

- ✔ V-PAD 1 x set: 2 Magnetic angles
- ✔ MAG-TAB - 1 piece

Technical data

	Lifting force	Weight	No.
	[kg]	[kg]	
V-PAD	8	0,4	55019
MAG-TAB	8	0,2	53093

WANT TO KNOW MORE?

We are happy to advise you by telephone or with a personal appointment.

➔ T +49 (0) 71 71 92 505-0

➔ info@assfalg-metal.com



www.assfalg-metal.com

Assfalg GmbH

Buchstraße 149
73525 Schwäbisch Gmünd
Germany

Tel +49 (0) 71 71 92 505-0

Fax +49 (0) 71 71 92 505-50

assfalg

The Ace for Metal