

- Individual
- Work-relieving
- Economical

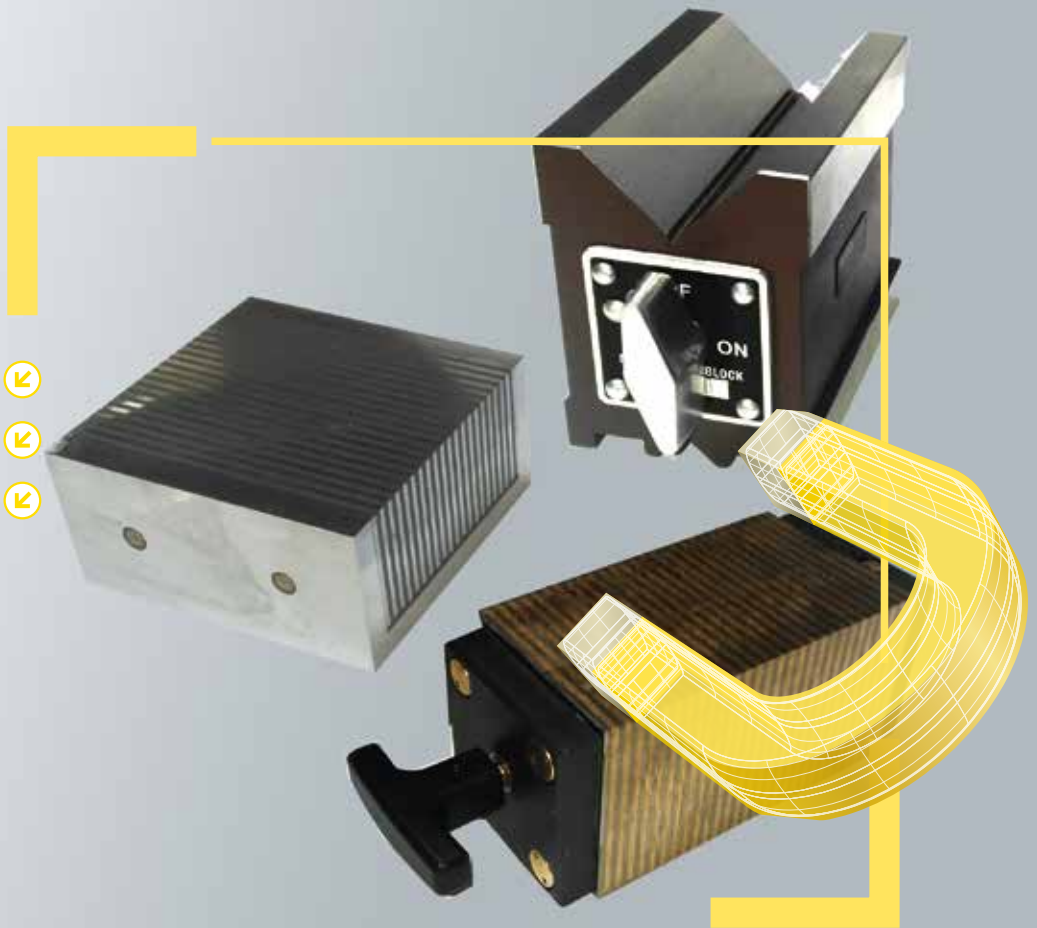

# Magnetic Accessories

## For individual application

ASSFALG Magnetic accessories for work-relieve, increased safety with every day work for lifting, transporting and separating of sheet-metal, filtration and demagnetization purposes.



The ACE for metal

**assfalg**

**Assfalg GmbH**

Buchstrasse 149  
D-73525 Schwäbisch Gmünd  
Germany

Phone +49 71 71.92 505-0

Fax +49 71 71.92 505-50

[info@assfalg-metal.com](mailto:info@assfalg-metal.com)

[www.assfalg-metal.com](http://www.assfalg-metal.com)

The right of changes and deviating pictures is reserved. Liability is excluded.

Design and production: Hela Werbung GmbH |  
[www.hela.com](http://www.hela.com)

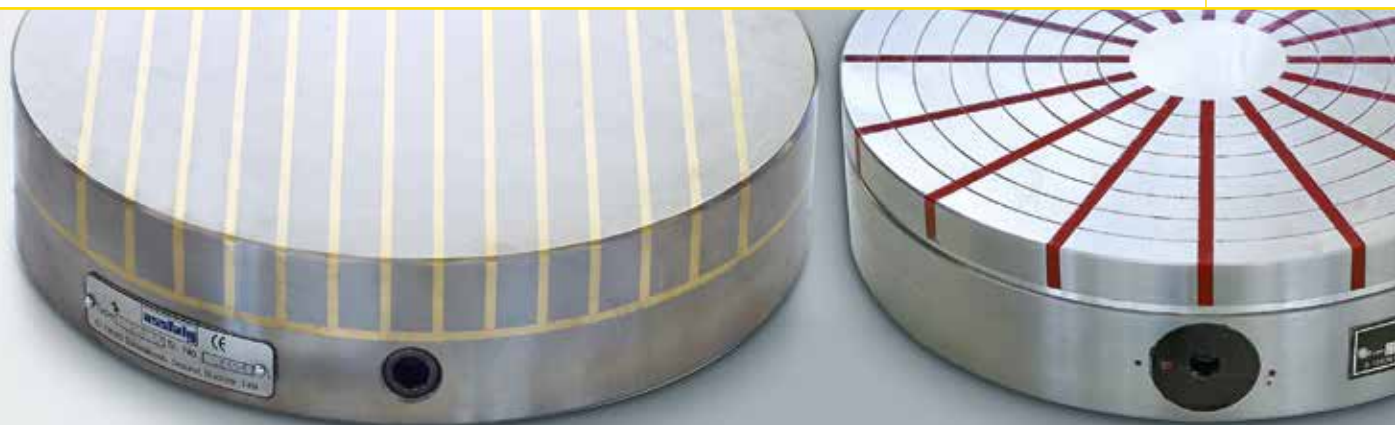

## Filtering | Lifting | Expanding | Demagnetizing | Mini magnets



Magnetic filter Micromag

03



Clamping magnets MSB

09

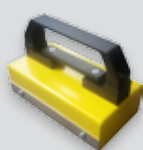

Filter bars  
Manual sorting magnet HSM

04



Switchable clamping mag-  
nets SBM

10

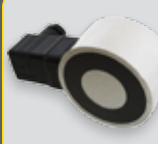

Electromagnets  
for automation

05

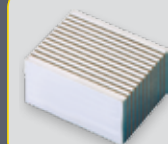

Segmented support modules

11

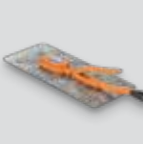

and hand-held magnetic  
pick-up

06

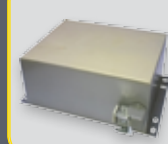

Demagnetizing plates  
Entmag-P

13



Sheet-metal separating magnets

07



Tunnel demagnetizers  
Entmag T

14



V-prisms

08



Mini magnets

15

# Magnetic filters Micromag

The magnetic filter Micromag provides for enormous filtration capacity with liquids, in particular with lubricating coolants.

Magnetic particles down to 0.2  $\mu\text{m}$  are filtered out by the permanent magnetic core. Sporadically appearing and non-magnetic parts are filtered out by means of the coagulation as well.

The filter can be easily incorporated in the coolant circuit through pipe threads.

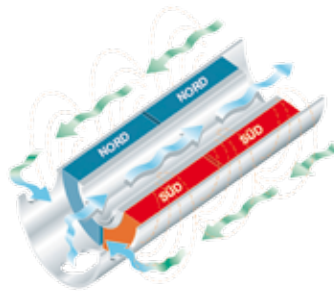

## Applications

- ▶ Grinding, honing and lapping machines
- ▶ CNC-machines
- ▶ Fine-finishing machines
- ▶ Electric discharge machines
- ▶ Laser cutting machines
- ▶ Building and industrial heating systems
- ▶ Pump protection

## Features

- ⌚ Huge filtration capacity
- ⌚ Easy and fast cleaning
- ⌚ Temperature range: +5°C to +50°C
- ⌚ Maximum operating pressure: 12 bar
- ⌚ Special designs from 0 - 80 bar are possible.
- ⌚ No extra costs - no additional disposal of filter media.

## Advantages

- ⌚ Improved drilling, grinding and electric discharge results
- ⌚ Longer lifetime of liquids
- ⌚ Prolonged lifetime of tools
- ⌚ Shorter maintenance and down times

## Technical data

	Flow rate	ø x length	Max. Dirt volume	Thread	Weight	Item no.
	[l/min]	[mm]	[kg]	[inch "]	[kg]	
Micromag MM5	70	80 x 125	1	1	2.5	46266
Micromag MM10	100	90 x 250	2	1	4.0	12514
Micromag MM20	150	90 x 500	4	1.5	8.0	45646

# Magnetic filter bar EGM

## Manual sorting magnet HSM

The magnetic filter bar EGM is used for extracting not only ferrous impurities from bulk material, plastic granulates, grain, corn, flour, food etc., but also for attracting of fluid materials.

The manual sorting magnet is preferably used for separating of bulk material and lifting of small parts such as bolts, nuts, nails or chips.



EGM



HSM ECO



HSM

### Applications

Magnetic filter bar:

- ▶ For cleaning of fluids

Manual sorting magnet

- ▶ For holding of small parts

### Features

Magnetic filter bar:

- ⌚ Cost-effective Extremely high adhesive forces with Neodymium-Iron-Boron-magnets
- ⌚ Low profile
- ⌚ Very cost-effective permanent magnet filter for occasional impurities

Manual sorting magnet:

- ⌚ Cost-effective
- ⌚ Longevity
- ⌚ Light-weight and compact design

Technical data	ø x length	Recommended lifting force	Weight	Item no.
	[mm]		[kg]	
Magnetic filter bar				
EGM-20	25x195*	For small parts only	0.5	48540

Technical data	Supporting surface	Overall height	Weight	Item no.
	[mm]	[mm]	[kg]	
Sorting magnet				
HSM	188x105	130	1,7	64760
HSM ECO	155x135	205	2,6	21899

\*Additional sizes on request

# Electric adhesive magnets for automation

These electric adhesive magnets are used for specific and electrically controllable holding / loosening of loads in manipulating and conveying equipment.

The adhesive magnets are available in 2 versions:

- Holding (H): Electric adhesive magnets that start magnetising and work holding only when energy is fed.
- Loosening (L): For this purpose, permanent adhesive magnets are used that release workpieces only when energy is fed.

Type A: With strand, 500 mm long



Type B: 2-pin clamp terminal



Types C + D: Hirschmann connector with rectifier (C) without rectifier (D)

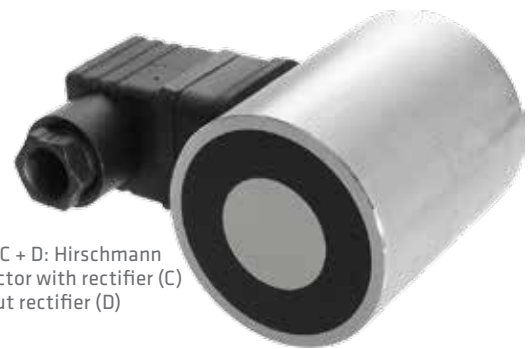

## Applications

- ▶ For holding & loosening of ferromagnetic work pieces
- ▶ In production, fixture and special-purpose machine building as well as automation and safety technology
- ▶ For fully and semi-automatic manipulating and conveying equipment

## Features

- ⌚ The holding force obtainable with low voltage 12V & 24V d.c or 240V a.c.
- ⌚ depends on both material thickness and surface finish (air gap).
- ⌚ Compact design

## Technical data

	Diameter	Height	Adhesive force	Voltage	Power consumption	Weight	Type
Holding current	[mm]	[mm]	[N]	[V]	[W]	[kg]	
M521-72 H	25	20	113	12	2.16	0.07	A
M521-72 H	25	20	113	24	2.16	0.07	A
M521-73 H	30	24	253	12	3.36	0.11	A
M521-73 H	30	24	253	24	3.36	0.11	A
M521-74 H	40	27	575	12	5.5	0.21	B
M521-74 H	40	27	575	24	5.5	0.21	B
M521-75 H	50	30	1097	12	5.7	0.36	B
M521-75 H	50	30	1097	24	5.7	0.36	B
M521-75 H	50	30	1097	240	8.56	0.41	C
M521-76 H	65	35	1677	12	8.2	0.71	B
M521-76 H	65	35	1677	24	8.2	0.71	B
M521-76 H	65	35	1677	240	10.7	0.74	C
<b>Loosening current</b>							
M521-77 L	35	48	285	24	5.5	0.35	D
M521-77 L	35	48	285	240	5.5	0.35	C
M521-78 L	50	63	471	24	8.5	0.87	D
M521-78 L	50	63	471	240	8.5	0.88	C

# Pick-and-place gripper & Manual pick-up magnet

These devices enable securely picking-up curved work pieces, and placing them in presses as well as punching tools and unloading them, then.

The hands remain outside the hazard zone - accidents are avoided.



HCM2



HM1



PM1



Helios



ELM 100-H

## Applications

- ▶ For secure lifting and transporting of sheet-metal, flame-cut parts as well as sharp-edged and greasy work pieces.

## Features

### Generals

- ⚙ Maximum safety due to permanent magnets
- ⚙ Heat-resistant up to 80°C
- ⚙ Easy loosening by mechanical ejector or leverage ELM

### ELM 100-H

- ⚙ Picking-up of checker plates is possible.

Technical data	Adhesive area / length	Lifting force	Towing force	Sheet-metal thickness	Weight	Item no.
	[mm]			[mm]		
Helios 335	19 / 235	2	-	> 0.3	0.3	335
Helios 336	25 / 235	3	-	> 0.3	0.4	336
PM 1	65 x 300	5	-	> 0.3	0.4	342
HM 1	58 x 30	5	7	> 0.3	0.2	98
HCM 2	90 x 50	20	6	> 0.5	1.0	20057
ELM 100-H	84 x 60	100	40	> 15/10	3.0	45019

# Sheet-metal separating permanent magnets

These separating magnets part stacked sheet-metal plates by permanent magnetic force. Each sheet plate can be picked up as single part by hand, lifting magnet or vacuum lifter.

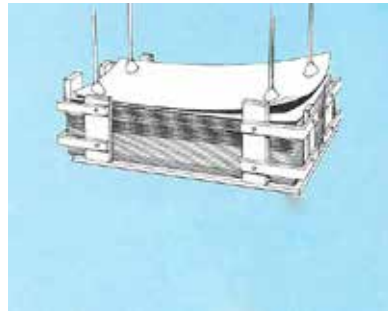
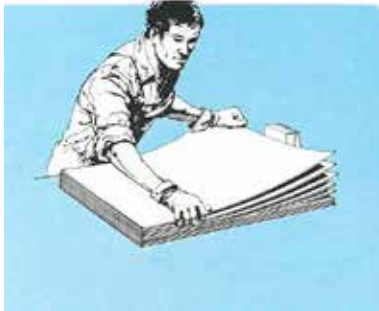

## Applications

- ▶ De-stacking / separating of stacked sheet-metal plates
- ▶ Ideal for extracting ferrous impurities from bulk material

## Features

- 🕒 Large penetration depth
- 🕒 Good air gap bridging

## Technical data

Technical data	Dimensions	Number of threads	Item no.
	[mm]		
92.07.073	75 x 73 x 28	2	122
<b>92.10.103</b>	<b>104 x 103 x 28</b>	<b>2</b>	<b>123</b>
<b>92.13.105</b>	<b>143 x 104 x 49</b>	<b>2</b>	<b>124</b>
92.26.105	277 x 104 x 49	2	126
92.30.105	310 x 104 x 49	2	127
92.35.105	344 x 104 x 49	2	128
92.40.105	411 x 104 x 49	3	129
92.45.105	444 x 104 x 49	3	12692
92.50.105	511 x 104 x 49	3	130
<b>PSC 210 Nd</b>	<b>210 x 155 x 50</b>	<b>2</b>	<b>12689</b>
PSC 220	220 x 183 x 77	2	42568
PSC 270	270 x 183 x 77	2	42569
<b>PSC 310 Nd</b>	<b>310 x 154 x 47</b>	<b>2</b>	<b>51403</b>
PSC 320	320 x 183 x 77	2	42570
PSC 420	420 x 183 x 77	3	42577



# Magnetic prisms

The V-shape magnetic prisms are employed for grinding and electric discharge jobs as well as useful helpers in metrology rooms when round and complex work pieces are to be safely and precisely clamped.



E934



PMP100



PMP75

## Applications

- ▶ For holding of cylindrical and complex work pieces
- ▶ Ideal for grinding and electric discharge machining tasks.

## Features

- ⚙ Four magnetic clamping surfaces (upper, lower and lateral surfaces)
- ⚙ Switchable on and off
- ⚙ Can be rapidly and easily placed.
- ⚙ Also deliverable as match-ground in pairs

## Technical data

	Dimensions (L x W x H)	max $\varnothing$	min $\varnothing$	Tolerance	Weight	Item no.
	[mm]	[mm]	[mm]	[ $\mu$ m]	[kg]	
<b>PMP75 (Pair)</b>	<b>75x75x56</b>	<b>40</b>	<b>5</b>	<b>5</b>	<b>1.79</b>	<b>62672</b>
<b>PMP100 (Pair)</b>	<b>100x95x70</b>	<b>65</b>	<b>5</b>	<b>5</b>	<b>3.96</b>	<b>62673</b>
E934	101.6 x 70 x 95.5	65	22	25	1.98	319
E934 (Pair)	101.6 x 70 x 95.5	65	22	25	1.98	18749
E933A	120 x 70 x 95	65	22	10	4.4	62130
E933A (Pair)	120 x 70 x 95	65	22	10	4.4	62963

# Permanent clamping magnets

The permanent clamping magnets MSB are used for clamping of shaped parts and grinding of cemented carbide.



MSB

MSB

## Applications

- ▶ For clamping of shaped parts
- ▶ For grinding of cemented carbide (type SmCo)

## Features

- Ⓛ Permanently magnetic
- Ⓛ Not switchable
- Ⓛ Mechanically machineable

## Technical data

	Dimensions (L x W x H) [mm]	Magnetic adhesive areas	Item no.
MSB	100x100x50	1 x 100x100 mm	314
MSB	100x50x50	2 x 100x50 mm	315
MSB	100x25x25	2 x 100x25 mm	316
For grinding of cemented carbide			
MSB...SmCo	100x100x50	2 x 100x50 mm	33477
MSB...SmCo	100x50x50	1 x 100x50 mm	33478
MSB...SmCo	100x25x25	2 x 100x25 mm	33479

# Clamping magnets

The clamping magnets SPM belong to useful accessories for clamping of small parts.



SPM Eco



SPM 2 L

SPM 2

## Applications

- ▶ Ideal for grinding and electric discharge machining, measuring and testing jobs
- ▶ Small magnetic workpieces from 0.5 mm can be clamped.

## Features

- ⌚ Magnetizable on all four longitudinal sides (SPM 2 L, SPM 2)
- ⌚ Short payback period
- ⌚ Universally applicable
- ⌚ Absolutely water-proof
- ⌚ Switchable on and off by pivoted lever
- ⌚ All four sides are regrindable (SPM 2 L, SPM 2)

## Technical data

	Dimensions (L x W x H)	Adhesive force	Weight	Item no.
	[mm]	[N/cm <sup>2</sup> ]	[kg]	
SPM 2	175x64x64	80	3.2	309
SPM 2 L	195x64x64	80	3.8	28983
Non-corrosive				
SPM2 NiRo	175x64x64	50	3.2	28984
SPM 2 L NiRo	195x64x64	50	3.8	51915
SPM Eco 3 magnetic adhesive areas	150x70x85	50	5	63363

# Segmented support modules

The segmented support modules effect as pole extension with magnetic clamping plates. Due to the machined shapes, complex work pieces can be magnetically clamped. Various working heights can be built-up as well.

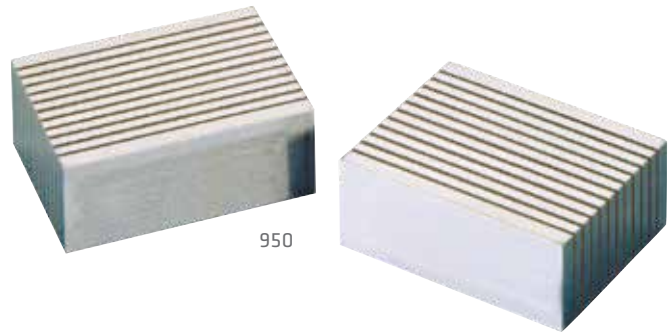

950



Set of segmented support modules



EHT-150

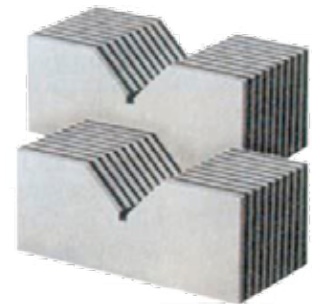

950v

## Applications

- ▶ The magnetic contact surface area between work piece and magnetic clamping plate can be enlarged with non-machined and machined segmented support modules.

## Features

- ⚙ The modules can be individually tailored to the work requirements.
- ⚙ Match-ground in pairs
- ⚙ Can be used both horizontally and vertically.

## Technical data

	Dimensions (L x W x H)	Pole alignment	Item no.
	[mm]		
950 (Pair)	60 x 75 x 30	longitudinal	62135
950 (Pair)	50 x 100 x 40	longitudinal	62136
EHT-100	100 x 70 x 40	transverse	
EHT-150	150 x 75 x 25	transverse	
EHT-300	300 x 75 x 25	transverse	
Pole block	Different sizes	longitudinal + transverse	

\*Additional sizes on request

# Introduction of demagnetizing

## Why demagnetizing?

All the ferrous and ferromagnetic materials are able forming magnetic zones due to, for example, raw material storage, magnetic crack and hardness tests, cold forming, chip cutting, magnetic clamping, lifting and measuring. Basically, magnetism is not harmful, but may prove interfering with further processing. Hand, plate and tunnel demagnetizers are available.



Hand demagnetizer

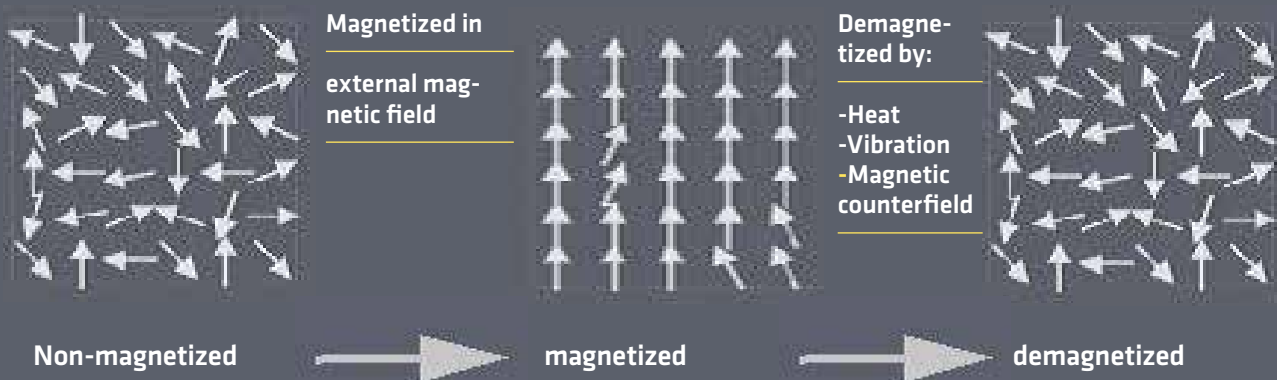

Plate demagnetizer



Tunnel demagnetizer

## Demagnetizing



While demagnetizing, the magnetic field in the workpiece gets neutralised. The work piece is magnetically neutral. The demagnetizing effect can be obtained by intense heating or a very strong external magnetic field. After demagnetization, the magnetic forces in the workpiece have disappeared. The magnetic field can be restored through remagnetization.

# Demagnetizing plate ENTMAG-P

ENTMAG demagnetizing plates are a simple and cost-effective solution for the demagnetization of single and series parts of small and medium size. The devices demagnetize up to a maximum distance of 60 mm. The work pieces are demagnetized either as single units fed by hand or conveyor. Clusters are to be avoided.

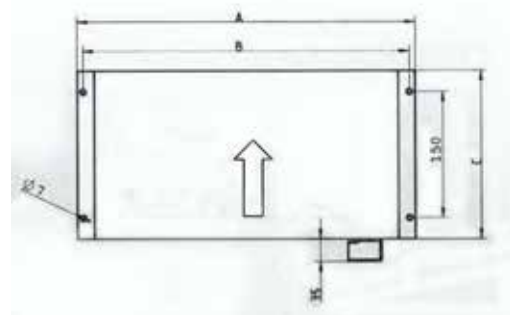
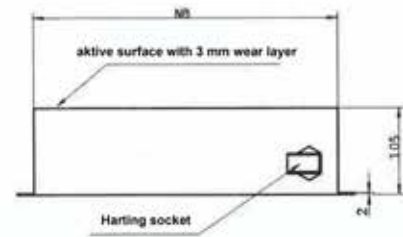

EDH 123



EDS 200

## Applications

- ▶ Neutralization of interfering residual magnetism.
- ▶ Demagnetizing is terminated after leaving the plate at a distance of appr. 300 mm.

## Features

- Ⓛ Robust, humidity-proof design (V2A-case).
- Ⓛ Suitable for work pieces made of soft and medium-hard material. High-grade hardened, intricate parts are recommended to be tried out before.
- Ⓛ All operating voltages at 50Hz or 60Hz are deliverable (lower frequency or pulse recurrence frequency for problematic cases).
- Ⓛ Connecting line, 2 m long, with plug connector.
- Ⓛ Type 17 designed for incorporation in belt conveyors (flow-line production).
- Ⓛ Conveying rate for demagnetizing <math><0.5\text{ m/s}</math>
- Ⓛ Demagnetization can penetrate deeper than 0.5 mT (5 Gauss). Test: Iron filings must not adhere on the work piece.

## Technical data

	Active area [mm]		Dimensions [mm]			Weight [kg]	Volt [V]	ED [%]	Item no.
	NB x C	A	B	H					
P 171	225 x 180	260	244	180	20	400	100	64408	
P 17.2	355 x 190	396	380	190	34	400	80		
P 17.3	425 x 190	466	450	190	41	400	80		
EDH 123	123 x 83	123	83	83	1.8	230	50	42161	
EDS 200	200 x 150	200	150	100	8.5	230	100	42176	

# Tunnel demagnetizer ENTMAG-T



ENTMAG-T tunnel demagnetizers enable simple and fast demagnetization of ferromagnetic small and large-number parts. The work piece is moved through the inner space of the tunnel by hand, chute or free fall. Demagnetizing is terminated only after leaving the plate at a distance of appr. 300 mm. The work pieces are recommended to be demagnetized one by one. Clusters are to be avoided.

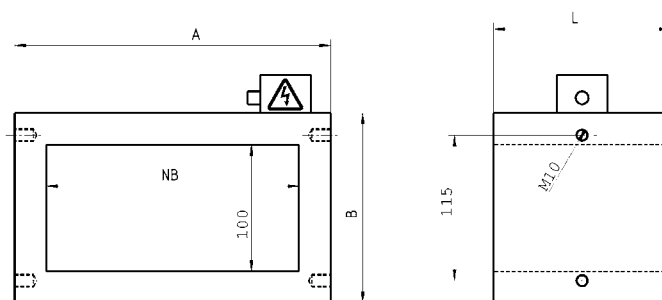

## Applications

- ▶ Preferred for demagnetization of small and large-number parts.
- ▶ The penetration depth into the work piece amounts to appr. 6 mm. The layer thickness with large-number parts must not exceed 6 mm.

## Features

- ⚡ Robust, humidity-proof design
- ⚡ Type 163: Suitable for work pieces made of soft material. Type 164: Suitable for work pieces made of medium hard material. Special: High-grade hardened, intricate parts are recommended to be tried out before.
- ⚡ All operating voltages at 50Hz or 60Hz are deliverable (lower frequency or pulse recurrence frequency for problematic cases).
- ⚡ All effective widths NB are deliverable from 150 to 800 mm.
- ⚡ Demagnetization can penetrate deeper than 0.5 mT (5 Gauss). Test: Iron filings must not adhere on the work piece.

## Technical data

	Dimensions [mm]					Weight [kg]	Item no.
	H	NB	L	A	B		
T 163	100	200	140	300	190	16	64153
T 163	100	400	140	500	190	24	
T 163	150	400	190	500	240	34	64181
T 164	100	200	140	320	210	29	
T 164	100	400	140	520	210	45	62592
T 164	150	400	190	520	260	59	65157

# Cylindrical gripper magnets

Cylindrical gripper magnets made from magnetic steel, with galvanized case

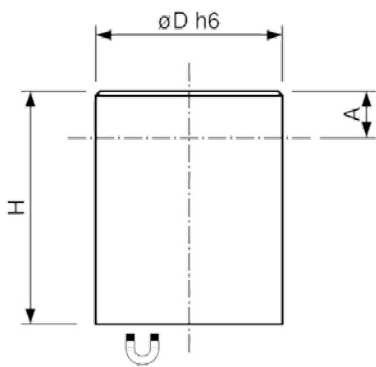

## Applications

- ▶ **001 AlNiCo:** Material: AlNiCo fit tolerance h6, max. admissible temperature 450° C
- ▶ **100 AlNiCo:** Material: AlNiCo without fit tolerance, max. admissible temperature 450° C

## Technical data

	Dimensions [mm]			Adhesive force [N]	Weight [g]	Item no.
	D	H	A			
Type 001 AlNiCo	6	10	2	2	2	208
	8	12	3	4	4	209
h6	10	16	6	8.5	9	210
	13	18	6	12	17	211
	16	20	6	20	29	212
	20	25	5	40	57	213
	25	30	7	60	110	214
	32	35	4	160	200	215
	40	45	5	240	420	216
	50	50	-	400	720	217
Type 100 AlNiCo	6	20	12	2	4.5	218
	8	20	11	4	7.5	219
without fit tolerance	10	20	10	8.5	12	220
	13	20	8	12	19	221
	16	20	6	20	30	222
	20	25	5	40	57	223
	25	35	13	60	125	224
	32	40	9	160	220	225
	40	50	10	240	440	226
	50	60	10	400	813	227



# Cylindrical gripper magnets

Cylindrical gripper magnets made of high-energy magnetic material

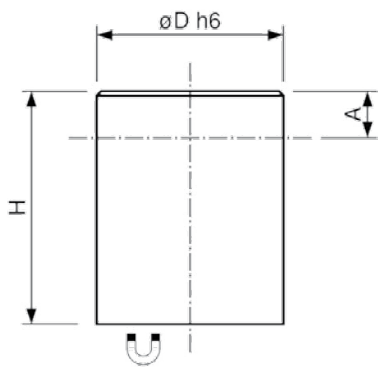

600 Co

600 Nd

## Applications

- ▶ **600 Co:** Material Cobalt-Samarium; fit tolerance h6; max. admissible temperature 200°C; brass case
- ▶ **100 Ne:** Material Neodymium; fit tolerance h6; max. admissible temperature 80°C; brass case

## Technical data

	Dimensions [mm]			Adhesive force [N]	Weight [g]	Item no.
	D	H	A			
Type 600 Co	6	20	10	8	4.5	265
h6	8	20	10	22	8	266
	10	20	8	40	12	267
	13	20	6	60	20	268
	16	20	2	125	30	269
	20	25	5	250	60	270
	25	35	7	400	135	2582
	32	40	4.5	600	250	272
Type 600 Nd	6	20	10	10	4.5	26232
h6	8	20	10	25	8	26233
	10	20	8	45	12	26234
	13	20	6	70	20	26235
	16	20	2	150	30	26236
	20	25	5	280	59	26237
	25	35	7	450	132	26238
	32	40	4.5	700	246	26239

# Flat gripper magnets

## with threaded bush

Flat gripper magnet with galvanized case, with threaded bush.

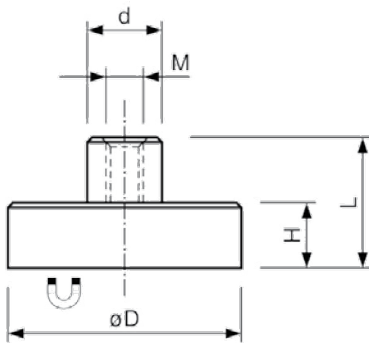

500 Fe



500 Co



500 Nd

### Applications

- ▶ 500 Fe: Material Ferrit; max. admissible temperature 200°C
- ▶ 500 Co: Material cobalt-samarium; max. admissible temperature 200°C
- ▶ 500 Ne: Material Neodymium; max. admissible temperature 80°C;

### Technical data

	Dimensions [mm]				Thread	Adhesive force [N]	Weight [g]	Item no.
	D	H	L	d				
500 Fe	10	4.5	11.5	6	M3	4	3	249
	13	4.5	11.5	6	M3	10	4	250
	16	4.5	11.5	6	M3	18	6	251
	20	6.0	13.0	6	M3	30	11	252
	25	7.0	15.0	8	M4	40	20	253
	32	7.0	15.0	8	M4	80	32	254
	40	8.0	18.0	10	M5	125	60	255
	50	10.0	22.0	12	M6	220	110	256
	63	14.0	30.0	15	M8	350	240	257
500 Co	80	18.0	34.0	20	M10	600	500	258
	100	22.0	43.0	22	M12	900	940	259
	125	26.0	50.0	25	M14	1300	1700	260
	6	4.5	11.5	6	M3	5	2	26199
	8	4.5	11.5	6	M3	11	3	26200
	10	4.5	11.5	6	M3	20	4	26201
	13	4.5	11.5	6	M3	40	6	26202
	16	4.5	11.5	6	M4	60	7	26203
500 Nd	20	6.0	13.0	8	M4	90	16	26204
	25	7.0	14.0	8	M4	150	28	26205
	32	7.0	15.5	10	M5	220	47	26206
	6	4.5	11.5	6	M3	5	2	26183
	8	4.5	11.5	6	M3	13	3	26184
	10	4.5	11.5	6	M3	25	4	26185
	13	4.5	11.5	6	M3	60	5	26186
	16	4.5	11.5	6	M4	95	7	26187
	20	6.0	13.0	8	M4	140	16	26188
	25	7.0	14.0	8	M4	200	27	26189
	32	7.0	15.5	10	M5	350	45	26190

# Flat gripper magnets

## without threaded bush

Flat gripper magnet with galvanized case, without threaded bush.

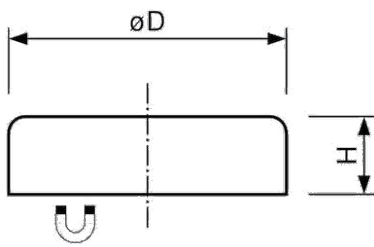

500 Fe

500 Co

500 Nd

### Applications

- ▶ 500 Fe: Material Ferrit; max. admissible temperature 200°C
- ▶ 500 Co: Material cobalt-samarium; max. admissible temperature 200°C
- ▶ 500 Ne: Material Neodymium; max. admissible temperature 80°C;

### Technical data

	Dimensions [mm]		Adhesive force [N]	Weight [g]	Item no.
	D	H			
500 Fe	10	4.5	4	2	238
	13	4.5	10	3	239
	16	4.5	18	5	240
	20	6.0	30	10	241
	25	7.0	40	18	242
	32	7.0	80	29	243
	40	8.0	125	55	244
	50	10.0	220	102	245
	63	14.0	350	226	246
500 Co	80	18.0	600	468	247
	100	22.0	900	915	9601
	125	26.0	1300	1680	35
	6	4.5	5	1	26191
	8	4.5	11	2	26192
	10	4.5	20	3	26193
	13	4.5	40	4	26194
	16	4.5	60	7	26195
500 Nd	20	6.0	90	14	26196
	25	7.0	150	26	26197
	32	7.0	220	42	26198
	6	4.5	5	1	26169
	8	4.5	13	2	26170
	10	4.5	25	2.5	26171
	13	4.5	60	4	26172
	16	4.5	95	6	26179
	20	6.0	140	14	26180
	25	7.0	200	25	26181
	32	7.0	350	41	26182

# Flat gripper magnets

with internal thread / with countersink / with cylindrical bore

Flat adhesive magnet made from magnetic steel, with galvanized case

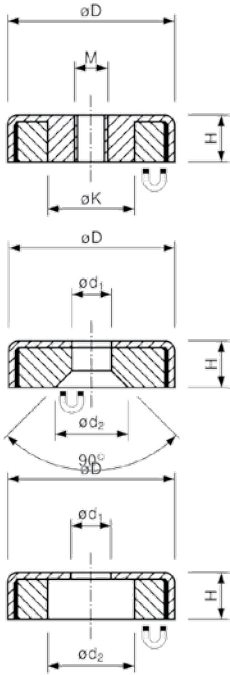

200 Fe

700 Fe with countersink

700 Fe with cylindrical bore

## Applications

- ▶ 200 Fe: Material Ferrit; max. admissible temperature 200°C
- ▶ 700 Fe: Material Ferrit; max. admissible temperature 200°C

### Type 200 Fe

	Dimensions [mm]			Thread	Adhesive force [N]	Weight [g]	Item no.
	D	H	K				
with internal thread	50	10	12.0	M 6	170	170	33888
	63	14	13.0	M 8	290	206	33887
	80	18	14.5	M 8	550	472	33886
	80	18	14.5	M 10	550	466	33788

### Type 700 Fe

	Dimensions [mm]				Adhesive force [N]	Weight [g]	Item no.
	D	H	d1	d2			
with countersink	16	4.5	3.5	6.5	14	4	22504
	20	6.0	4.2	9.4	27	9	22505
	25	7.0	5.5	11.5	36	16	22506
	32	7.0	5.5	11.5	72	27	11799
	40	8.0	5.5	11.5	90	53	15091
with cylindrical bore	50	10.0	8.5	22	180	90	22494
	63	14.0	6.5	24	290	195	22490
	80	18.0	6.5	11.5	540	478	22493

# Flat gripper magnets

## with hook / with stud bolt

Flat adhesive magnet made from magnetic steel, painted / galvanized case

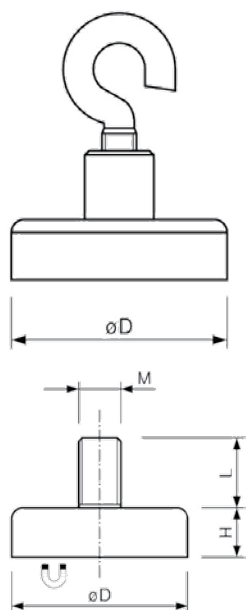

DMAG

200 Fe

### Applications

- ▶ **DMAG:** Material Ferrit; max. admissible temperature 200°C, with hook
- ▶ **20 Fe:** Material Ferrit; max. admissible temperature 200°C, with stud bolt

### Type DMAG

	Dimensions [mm]	Thread	Adhesive force [N]	Weight [g]	Item no.
	D				
with hook	25	M 4	40	23	41213
	32	M 4	80	34	41214
	40	M 4	125	59	41215
	50	M 4	220	107	41216

### Type 200 Fe

	Dimensions [mm]			Thread	Adhesive force [N]	Weight [g]	Item no.
	D	H	L				
with stud	10	4.5	7	M 3	4	2	22498
bolt	13	4.5	7	M 3	10	3	22499
	16	4.5	7	M 3	20	5	22500
	20	6.0	7	M 3	30	10	22501
	25	7.0	8	M 4	40	19	22502
	32	7.0	8	M 4	80	30	22503

# Magnetic clamps

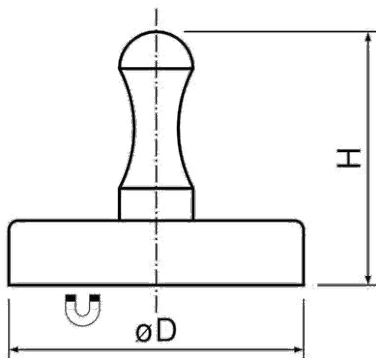

OMAG

GMAG

## Applications

- ▶ **OMAG:**Material Ferrit, plastic-coated
- ▶ **GMAG:**Material Ferrit, white painted

## Type OMAG

Dimensions [mm]	yellow	red	green	blue	black	white
D						
25	275	277	278	279	273	274
29	282	284	285	286	17016	281
35	293	295	296	297	53188	53189

## Type GMAG

Dimensions [mm]		Surface	Adhesive force [N]	Weight [g]	Item no.
D	H				
12	16.0	nickel-plated	55	7	36490
25	22.0	white painted	40	25	26175
32	22.0	white painted	80	35	26176
36	29.5	white painted	100	45	26177
40	29.5	white painted	125	62	26178

# Button, pot U-magnets

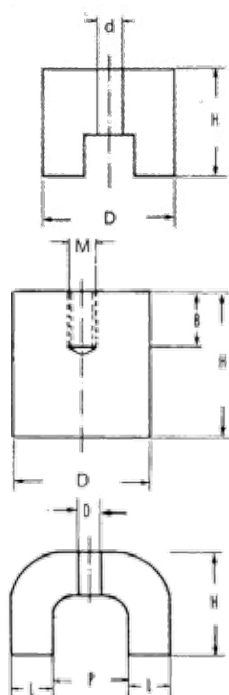

## Applications

- ▶ Button magnets, through bore, divided adhesive area, material AlNiCo; max. admissible temperature 450°C
- ▶ Pot magnets Material: AlNiCo with thread; max. admissible temperature 450°C
- ▶ U-magnets: Material AlNiCo; max. temperature 450°C

## Technical data

	Dimensions [mm]		Bore / thread [mm]	Adhesive force [N]	Weight [g]	Item no.
	D	H	d/M			
Button magnets	13	10	4.2	7	7	180
	19	13	5.4	19	20	181
	25	16	5.4	29	56	182
	32	25	7	66	133	183
Pot magnets	19	8	3.5	30	18	184
	29	9	5	55	46	185
	38	10.5	5	95	97	186
	17	16	M 6	18	26	188
	21	19	M 6	28	50	189
	27	25	M 6	65	110	190
	35	30	M 6	120	215	191

## Technical data

	Total	Dimensions [mm]				Adhesive force [N]	Weight [g]	Item no.
		L	P	B	H			
U-magnets	31	8	15	20	20	45	65	173
	40	10	20	25	25	90	150	174
	44	11	22	29	30	120	220	175
	57	11	35	35.5	35	230	380	176
	71	15	41	57	41	320	1600	177
	78	15	48	82	54.5	470	2000	178

WOULD YOU LIKE TO KNOW MORE?

**We will be happy to advise you. By phone or in a personal meeting.**

➔ T +49 71 71.92 505-0

➔ [info@assfalg-metal.com](mailto:info@assfalg-metal.com)



[www.assfalg-metal.com](http://www.assfalg-metal.com)

**Assfalg GmbH**

Buchstrasse 149  
D-73525 Schwäbisch Gmünd  
Germany

Phone +49 71 71.92 505-0

Fax +49 71 71.92 505-50

**assfalg**

The ACE for metal